

CentreCOM® GS970EMX Series

Gigabit Layer 3 Lite Access Switches with 10 Gigabit Uplinks

GS970EMX/10

GS970EMX/20

GS970EMX/28

GS970EMX/52

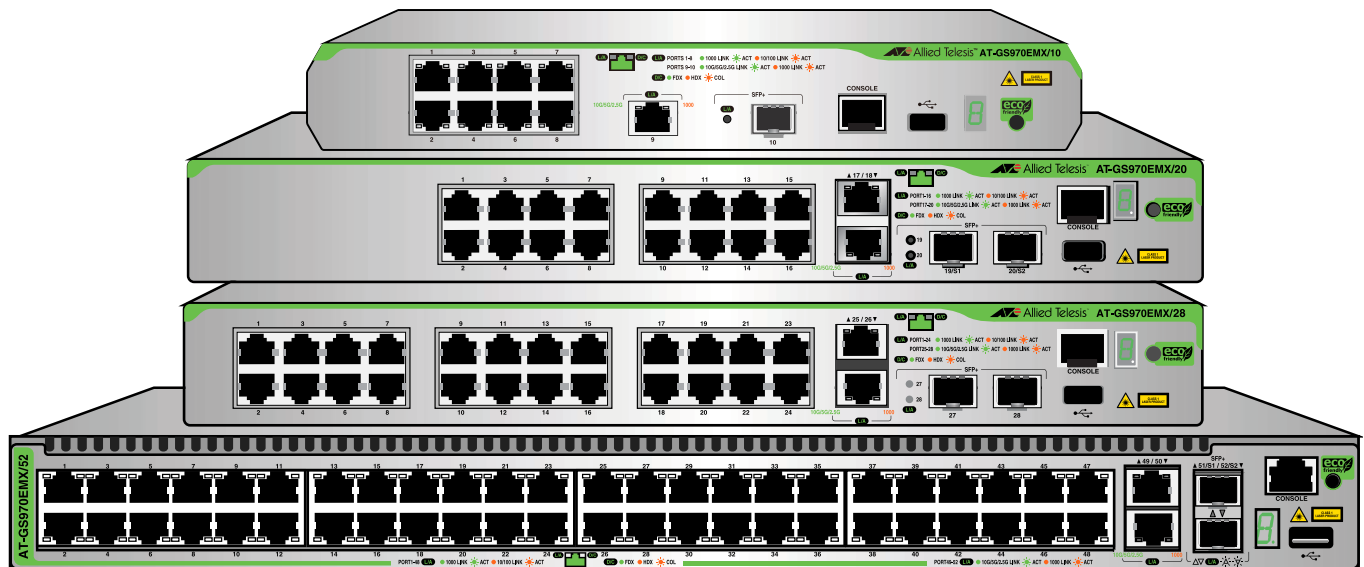

Installation Guide for Virtual Chassis Stacking

Copyright © 2023 Allied Telesis, Inc.

All rights reserved. No part of this publication may be reproduced without prior written permission from Allied Telesis, Inc.

Allied Telesis, VCStack, Allied Telesis logo, and CentreCOM are trademarks or registered trademarks of Allied Telesis, Incorporated. All other product names, company names, logos or other designations mentioned herein are trademarks or registered trademarks of their respective owners.

Allied Telesis, Inc. reserves the right to make changes in specifications and other information contained in this document without prior written notice. The information provided herein is subject to change without notice. In no event shall Allied Telesis, Inc. be liable for any incidental, special, indirect, or consequential damages whatsoever, including but not limited to lost profits, arising out of or related to this manual or the information contained herein, even if Allied Telesis, Inc. has been advised of, known, or should have known, the possibility of such damages.

Electrical Safety and Emissions Standards

This product meets the following standards.

U.S. Federal Communications Commission
<p>Radiated Energy</p> <p>Note: This equipment has been tested and found to comply with the limits for a Class A digital device pursuant to Part 15 of FCC Rules. These limits are designed to provide reasonable protection against harmful interference when the equipment is operated in a commercial environment. This equipment generates, uses, and can radiate radio frequency energy and, if not installed and used in accordance with this instruction manual, may cause harmful interference to radio communications. Operation of this equipment in a residential area is likely to cause harmful interference in which case the user will be required to correct the interference at his own expense.</p> <p>Note: Modifications or changes not expressly approved of by the manufacturer or the FCC, can void your right to operate this equipment.</p>

Industry Canada
<p>This Class A digital apparatus complies with Canadian ICES-003.</p> <p>Cet appareil numérique de la classe A est conforme à la norme NMB-003 du Canada.</p>



Warning

In a domestic environment this product may cause radio interference in which case the user may be required to take adequate measures. *see* E84

Electrical Safety: EN 62368-1 (UL/EN/IEC)



Laser Safety EN 60825-1

Table 1 lists the product certificates.

Table 1. Product Certifications

Additional Certificates	CISPR Class A (Comité International Spécial des Perturbations Radioélectriques) RoHS Compliant
Australia/New Zealand	RCM (Regulatory Compliance Mark)
Common Criteria	NIAP (National Information Assurance Partnership)

Table 1. Product Certifications (Continued)

European Economic Area (EEA)	CE (Conformité Européenne) WEEE (Waste Electrical and Electronic Equipment) RoHS (EU 1025/863) (Restriction of Hazardous Substances)
European Standards (EN)	EMC (Immunity): EN 55024, EN 55035 Laser Safety: EN 60825-1 EN 55032 Class A, EN 61000-3-2, EN 61000-3-3
India	TEC (Telecommunications Engineering Center)
Japan	VCCI Class A (Voluntary Control Council for Interference)
Mexico	NOM (Normas Oficiales Mexicanas)
North America	FCC Class A Laser Safety: EN 60825-1 cUL _{US} Energy Star
United Kingdom	UKCA (UK Conformity Assessment)

Translated Safety Statements

Important: Safety statements with the  symbol are translated into multiple languages in **Translated Safety Statements** at alliedtelesisis.com/library/search.

Übersetzte Sicherheitshinweise

Wichtig: Sicherheitshinweise mit dem -Symbol werden in **Translated Safety Statements** bei alliedtelesisis.com/library/search in mehrere Sprachen übersetzt.

Declaraciones de seguridad traducidas

Importante: Las declaraciones de seguridad con el símbolo  se traducen a varios idiomas en **Translated Safety Statements** en alliedtelesisis.com/library/search.

Consignes de sécurité traduites

Important: Les déclarations de sécurité avec le symbole  sont traduites en plusieurs langues en **Translated Safety Statements** sur alliedtelesisis.com/library/search.

Dichiarazioni di sicurezza tradotte

Importante: Le dichiarazioni di sicurezza con il simbolo  sono tradotte in più lingue in **Translated Safety Statements** su alliedtelesisis.com/library/search.

Översatta säkerhetsföklaringar

Viktig: Säkerhetsföreskrifter med -symbolen översätts till flera språk på **Translated Safety Statements** vid alliedtelesisis.com/library/search.

Contents

Preface	15
Document Conventions	16
Contacting Allied Telesis	17
Chapter 1: Overview	19
Front and Back Panels	20
Features	23
10/100/1000Mbps Copper Ports	23
1/2.5/5/10Gbps Multi-Gigabit Copper Ports.....	23
1/10Gbps SFP+ Ports	23
Port and System LEDs	24
Installation Options	24
MAC Address Table	24
Management Software and Interfaces	24
Energy Savings	25
10/100/1000Mbps Copper Ports.....	26
1/2.5/5/10Gbps Multi-Gigabit Copper Ports.....	28
SFP+ Ports	30
Port LEDs	31
10/100/1000Mbps Copper Port LEDs	31
1/2.5/5/10Gbps Multi-Gigabit Copper Port LEDs.....	33
1/10Gbps SFP+ Port LEDs	34
eco-friendly Button.....	36
Switch ID LED	37
USB Port.....	39
Console Port.....	40
Power Supply and Power Savings Features	41
Chapter 2: Virtual Chassis Stacking	43
Overview	44
Stacking Guidelines	45
Stack Trunks.....	46
SFP+ Ports S1 and S2	46
Multi-Gigabit Copper Ports	49
Unsupported Trunks	51
Master and Member Switches	54
Switch ID Numbers	55
Feature Licenses	56
Planning the Stack.....	57
Specifying Ports in the Command Line Interface.....	58
VCStack Worksheet	60
Chapter 3: Beginning the Installation	65
Reviewing Safety Precautions	66
Choosing a Site for the Switch	70
Site Requirements	70
Enclosure Requirements	71
Unpacking the Switch	72
Installation Options	75
GS970EMX/20 Switch	75
GS970EMX/28 Switch	76

GS970EMX/52 Switch	77
Hardware Options	78
RKMT-J13 Equipment Rack Brackets Kit	78
BRKT-J24 Wall Brackets Kit	79
Recording the Serial Number and MAC Address	80
Installing the Switch on a Table	81
Chapter 4: Installing the GS970EMX/20 Switch in an Equipment Rack	85
Introduction	86
Installing the GS970EMX/20 Switch	87
Chapter 5: Installing the GS970EMX/28 Switch in an Equipment Rack	91
Introduction	92
Installing the GS970EMX/28 Switch	93
Chapter 6: Installing the GS970EMX/52 Switch in an Equipment Rack	95
Introduction	96
Installing the GS970EMX/52 Switch	97
Chapter 7: Installing GS970EMX/20, GS970EMX/28, and GS970EMX/52 Switches on a Wall	99
Installation Guidelines	100
Plywood Base for a Wall with Wooden Studs	103
Installing the Switch	105
Chapter 8: Displaying the Hardware Status and AlliedWare Plus Version Number	109
Powering On the Switch	110
Starting a Local Management Session	112
Displaying the Hardware Status and AlliedWare Plus Version Number	115
Chapter 9: Building Stacks with SFP+ Ports S1 and S2	117
Introduction	118
Powering On the Switches Sequentially	119
Powering On the Switches Simultaneously	121
Verifying the Stack and Assigning Priority Numbers	123
Chapter 10: Building Stacks with Multi-Gigabit Copper Ports	127
Introduction	128
Command Summary	129
STACK ENABLE Command	129
STACKPORT Command	129
STACK PRIORITY Command	130
STACK RENUMBER Command	131
SWITCH PROVISION Command	132
Configuring the Master Switch	133
General Steps for the Master Switch	133
Configuring the Master Switch - Part I	134
Configuring the Master Switch - Part II	136
Verifying the Master Switch	138
What to Do Next	140
Configuring Member Switches	141
General Steps for Member Switches	141
Configuring Member Switches - Part I	142
Configuring Member Switches - Part II	143
Verifying Member Switches	145
What to Do Next for Member Switches	147
Powering On the Stack	148
Chapter 11: Cabling Copper and SFP+ Ports	149
Cabling Copper Ports	150
Guidelines to Handling SFP and SFP+ Transceivers	151
Installing 1Gbps SFP and 10Gbps SFP+ Transceivers	152
Installing SP10TW Direct Connect Twinax Cables in SFP+ Ports	155

Chapter 12: Troubleshooting	157
Appendix A: Technical Specifications	161
Physical Specifications	162
Environmental Specifications.....	166
Power Specifications	169
Certifications	171
RJ-45 Copper Port Pinouts.....	173
RJ-45 Style Serial Console Port Pinouts	174

Figures

Figure 1: Front Panel of the GS970EMX/10 Switch	20
Figure 2: Front Panel of the GS970EMX/20 Switch	20
Figure 3: Front Panel of the GS970EMX/28 Switch	21
Figure 4: Front Panel of the GS970EMX/52 Switch	21
Figure 5: Back Panels	22
Figure 6: Speed/Activity and Duplex Mode LEDs for the 10/100/1000Mbps Copper Ports.....	31
Figure 7: Speed/Activity LEDs for the 1/2.5/5/10Gbps Multi-Gigabit Copper Ports.....	33
Figure 8: Speed/Activity LEDs for the 1/10Gbps SFP+ Ports.....	34
Figure 9: Switch ID LED	37
Figure 10: Switch ID LED with eco-friendly Mode Off (Port LEDs On).....	37
Figure 11: Switch ID LED with eco-friendly Mode On (Port LEDs Off).....	38
Figure 12: Stack Trunks of SFP+ Ports S1 and S2 for Two Switches.....	47
Figure 13: Stack Trunks of SFP+ Ports S1 and S2 for Three Switches	47
Figure 14: Stack Trunks of SFP+ Ports S1 and S2 for Four Switches	48
Figure 15: Mixed Stack of GS970EMX Switches.....	48
Figure 16: Chain Stack Trunk of SFP+ Ports S1 and S2.....	49
Figure 17: Stack Trunks of Multi-Gigabit Copper Ports for Two Switches.....	49
Figure 18: Stack Trunks of Multi-Gigabit Copper Ports for Three Switches	50
Figure 19: Stack Trunks of Multi-Gigabit Copper Ports for Four Switches	50
Figure 20: Chain Stack Trunk of Multi-Gigabit Copper Ports.....	51
Figure 21: Unsupported Trunk of Multi-Gigabit Copper Ports and SFP+ Ports S1 and S2	51
Figure 22: Unsupported Trunk of SFP+ Ports S1 and S2 with Mixed Cables	52
Figure 23: Unsupported Trunk with a Network Device Between Trunk Ports.....	53
Figure 24: PORT Parameter in the Command Line Interface.....	58
Figure 25: Accessory Items Included with the GS970EMX/20 Switch.....	72
Figure 26: Accessory Items Included with the GS970EMX/28 Switch.....	73
Figure 27: Accessory Items Included with the GS970EMX/52 Switch.....	74
Figure 28: Installation Options for the GS970EMX/20 Switch	75
Figure 29: Installation Options for the GS970EMX/28 Switch	76
Figure 30: Installation Options for the GS970EMX/52 Switch	77
Figure 31: RKMT-J13 Equipment Rack Brackets Kit for the GS970EMX/20 Switch	78
Figure 32: BRKT-J24 Wall Brackets Kit for the GS970EMX/20 and GS970EMX/28 Switches	79
Figure 33: Serial Number and MAC Address Labels.....	80
Figure 34: Switch Installation on a Table.....	81
Figure 35: Unsupported Table Installations	81
Figure 36: Attaching the Bumper Feet	82
Figure 37: Attaching Bumper Feet on the GS970EMX/52 Switch	83
Figure 38: GS970EMX/20 Switch with RKMT-J13 Equipment Rack Brackets Kit.....	86
Figure 39: Attaching the Handles to the RKMT-J13 Brackets	87
Figure 40: Attaching the Extenders to the RKMT-J13 Brackets	88
Figure 41: Attaching the RKMT-J13 Brackets to the GS970EMX/20 Switch.....	88
Figure 42: Securing the GS970EMX/20 Switch in a Standard 19-inch Equipment Rack	89
Figure 43: GS970EMX/28 Switch Installed in a Standard 19-inch Equipment Rack.....	92
Figure 44: Attaching the Equipment Rack Brackets to the GS970EMX/28 Switch.....	93
Figure 45: Securing the GS970EMX/28 Switch in a Standard 19-inch Equipment Rack	94
Figure 46: Bracket Screw Holes on the GS970EMX/52 Switch.....	96
Figure 47: Equipment Rack Bracket Positions for the GS970EMX/52 Switch.....	96
Figure 48: Attaching the Equipment Rack Brackets to the GS970EMX/52 Switch.....	97
Figure 49: Securing the GS970EMX/52 Switch in a Standard 19-inch Equipment Rack	98

Figure 50: GS970EMX/20 and GS970EMX/28 Switches on a Wall with the BRKT-J24 Brackets Kit 100

Figure 51: GS970EMX/52 Switch on a Wall 100

Figure 52: Unsupported Wall Installation of the GS970EMX/20, GS970EMX/28, and GS970EMX/52 Switches 101

Figure 53: GS970EMX Switch on a Wall with a Plywood Base 103

Figure 54: Steps to Installing GS970EMX Switches on a Plywood Base 104

Figure 55: Attaching the BRKT-J24 Wall Brackets to the GS970EMX/20 and GS970EMX/28 Switches 106

Figure 56: Attaching the Wall/Equipment Rack Brackets to the GS970EMX/52 Switch 106

Figure 57: Attaching the Wall/Equipment Rack Brackets to the GS970EMX/52 Switch (continued) 107

Figure 58: Marking the Locations of the Bracket Holes 108

Figure 59: Installing the Power Cord Retaining Clip 110

Figure 60: Connecting the AC Power Cord 110

Figure 61: Lowering the Power Cord Retaining Clip 111

Figure 62: Connecting the Power Cord to an AC Power Outlet 111

Figure 63: Management Cable Included with Switch 112

Figure 64: VT-Kit3 Management Cable 112

Figure 65: Local Management with the VT-Kit3 Management Cable 113

Figure 66: Disconnecting the Power Cord from the AC Power Source 115

Figure 67: SHOW STACK Command 123

Figure 68: Moving to the Global Configuration Mode with the ENABLE and CONFIGURE TERMINAL Commands 124

Figure 69: Returning to the Privileged Exec Mode 125

Figure 70: Saving the Priority Values with the WRITE Command 125

Figure 71: SHOW STACK Command with New Switch Priority Values 125

Figure 72: SHOW STACK Command on the Master Switch 138

Figure 73: SHOW RUNNING-CONFIG INTERFACE Command on the Master Switch 139

Figure 74: Powering Off the Switch 140

Figure 75: SHOW STACK Command for a Member Switch 145

Figure 76: SHOW RUNNING-CONFIG INTERFACE Command for Member Switches 146

Figure 77: Installing an SFP+ Transceiver 152

Figure 78: Removing the Dust Cover from an SFP+ Transceiver 153

Figure 79: Positioning the SFP+ Handle in the Upright Position 153

Figure 80: Connecting a Fiber Optic Cable to an SFP or SFP+ Transceiver 154

Figure 81: Installing an SP10TW Cable 155

Figure 82: Dimensions of the GS970EMX/10 Switch 162

Figure 83: Dimensions of GS970EMX/20 and GS970EMX/28 Switches 163

Figure 84: Dimensions of the GS970EMX/52 Switch 163

Figure 85: Bracket Screw Holes on GS970EMX/20 and GS970EMX/28 Switches 164

Figure 86: Bracket Screw Holes on the GS970EMX/52 Switch 165

Figure 87: Pin Layout for the RJ-45 Copper Ports (Front View) 173

Tables

Table 1: Product Certifications	3
Table 2: Specifications of the 10/100/1000Mbps Copper Ports	26
Table 3: Specifications of the 1/2.5/5/10Gbps Multi-Gigabit Copper Ports	28
Table 4: Speed/Activity LEDs for the 10/100/1000Mbps Copper Ports	31
Table 5: Duplex Mode LEDs for the 10/100/1000Mbps Copper Ports	32
Table 6: Speed/Activity LEDs for the 1/2.5/5/10Gbps Multi-Gigabit Copper Ports	33
Table 7: Speed/Activity LEDs for the 1/10Gbps SFP+ Ports	35
Table 8: PORT Parameter Format	58
Table 9: VCStack Worksheet	60
Table 10: Stacking Worksheet Columns	60
Table 11: Stack Worksheet Example with SFP+ Ports as Stack Trunk	62
Table 12: Stack Worksheet Example with Multi-Gigabit Copper Ports as Stack Trunk	63
Table 13: Configuring the Master Switch for a Stack Trunk of Multi-Gigabit Copper Ports - Part I	134
Table 14: Configuring the Master Switch for a Stack Trunk of Multi-Gigabit Copper Ports - Part II	136
Table 15: Configuring Member Switches - Part I	142
Table 16: Configuring Member Switches - Part II	143
Table 17: Product Dimensions (H x W x D)	162
Table 18: Switch Weights	164
Table 19: Ventilation Requirements	164
Table 20: Storage and Operating Environment Specifications	166
Table 21: Operating Temperature Ranges	166
Table 22: Maximum Power Consumption	169
Table 23: Input Voltages	169
Table 24: Heat Dissipation	170
Table 25: Product Certifications	171
Table 26: Pin Signals for Copper Ports	173
Table 27: RJ-45 Style Serial Console Port Pin Signals	174

Preface

This guide contains the hardware installation instructions for the CentreCOM® GS970EMX/20, GS970EMX/28, and GS970EMX/52 Gigabit Ethernet Layer 3 Lite Access switches. The instructions explain how to install the switches in virtual stacks with Virtual Chassis Stacking (VCStack™). VCStack lets you manage multiple switches as a single unit and add redundancy to your network topology by distributing functions across multiple devices. This preface contains the following sections:

- “Document Conventions” on page 16
- “Contacting Allied Telesis” on page 17

Note

The GS970EMX/10 Switch is included in Chapter 1, “Overview” on page 19, but it does not support the VCStack feature.

For instructions on how to install GS970EMX Switches as standalone units, refer to the *CentreCOM® GS970EMX Series Installation Guide for Standalone Switches*.

Document Conventions

This document uses the following conventions:

Note

Notes provide additional information.



Caution

Cautions inform you that performing or omitting a specific action may result in equipment damage or loss of data.



Warning

Warnings inform you that performing or omitting a specific action may result in bodily injury.

Contacting Allied Telesis

For assistance with this product, you may contact Allied Telesis technical support on the Services & Support section of the Allied Telesis web site at **www.alliedtelesis.com/services-support**. The page has links to the following services:

- ❑ Helpdesk (Support Portal) - Log onto Allied Telesis interactive support center to search for answers to your questions in our knowledge database, check support tickets, learn about Return Merchandise Authorizations (RMAs), and contact Allied Telesis technical experts.
- ❑ Software Downloads - Download the latest software releases for your product.
- ❑ Licensing - Register and obtain your License key to activate your product.
- ❑ Product Documents - View the most recent installation guides, user guides, software release notes, white papers and data sheets for your product.
- ❑ Warranty - View a list of products to see if Allied Telesis warranty applies to the product you purchased and register your warranty.
- ❑ Allied Telesis Helpdesk - Contact a support representative.

Chapter 1

Overview

This chapter contains the following sections:

- ❑ “Front and Back Panels” on page 20
- ❑ “Features” on page 23
- ❑ “10/100/1000Mbps Copper Ports” on page 26
- ❑ “1/2.5/5/10Gbps Multi-Gigabit Copper Ports” on page 28
- ❑ “SFP+ Ports” on page 30
- ❑ “Port LEDs” on page 31
- ❑ “eco-friendly Button” on page 36
- ❑ “Switch ID LED” on page 37
- ❑ “USB Port” on page 39
- ❑ “Console Port” on page 40
- ❑ “Power Supply and Power Savings Features” on page 41

Note

The GS970EMX/10 Switch is included in this chapter, but it does not support the VCStack feature.

Front and Back Panels

Figure 1 shows the front panel of the GS970EMX/10 Switch.

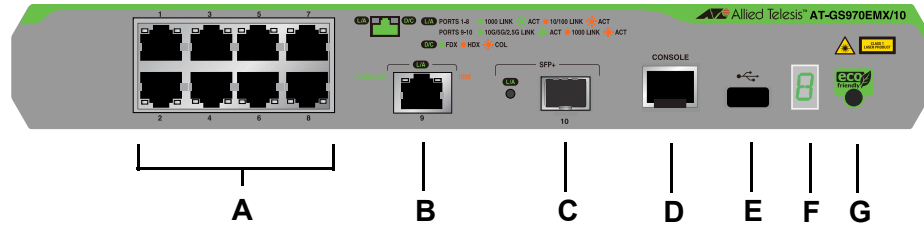

- | | |
|--|---|
| <p>A. Eight 10/100/1000Mbps Copper Ports</p> <p>B. One 1/2.5/5/10Gbps Multi-Gigabit Copper Port</p> <p>C. One 1/10Gbps SFP+ Transceiver Port</p> <p>D. One Local Management Console Port</p> | <p>E. One USB Flash Drive Port</p> <p>F. Switch ID LED</p> <p>G. eco-friendly Button</p> |
|--|---|

Figure 1. Front Panel of the GS970EMX/10 Switch

Figure 2 shows the front panel of the GS970EMX/20 Switch.

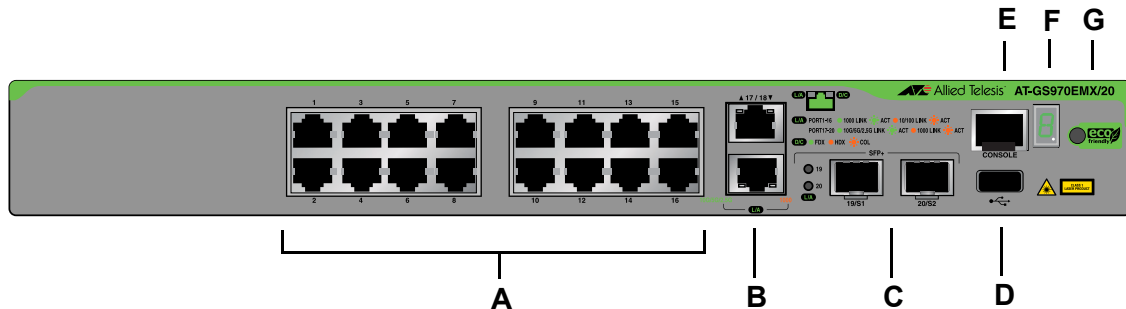

- | | |
|---|--|
| <p>A. Sixteen 10/100/1000Mbps Copper Ports</p> <p>B. Two 1/2.5/5/10Gbps Multi-Gigabit Copper Ports</p> <p>C. Two 1/10Gbps SFP+ Transceiver Ports</p> <p>D. One USB Flash Drive Port</p> | <p>E. One Local Management Console Port</p> <p>F. Switch ID LED</p> <p>G. eco-friendly Button</p> |
|---|--|

Figure 2. Front Panel of the GS970EMX/20 Switch

Figure 3 shows the front panel of the GS970EMX/28 Switch.

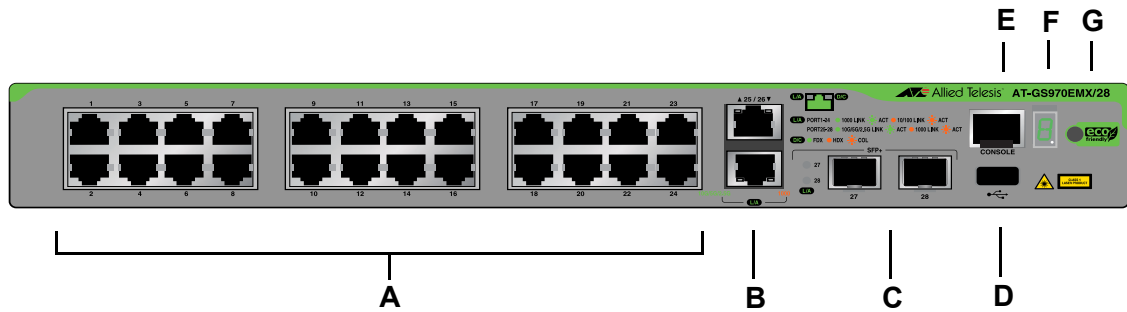

- | | |
|---|--|
| <p>A. Twenty-four 10/100/1000Mbps Copper Ports</p> <p>B. Two 1/2.5/5/10Gbps Multi-Gigabit Copper Ports</p> <p>C. Two 1/10Gbps SFP+ Transceiver Ports</p> <p>D. One USB Flash Drive Port</p> | <p>E. One Local Management Console Port</p> <p>F. Switch ID LED</p> <p>G. eco-friendly Button</p> |
|---|--|

Figure 3. Front Panel of the GS970EMX/28 Switch

Figure 4 shows the front panel of the GS970EMX/52 Switch.

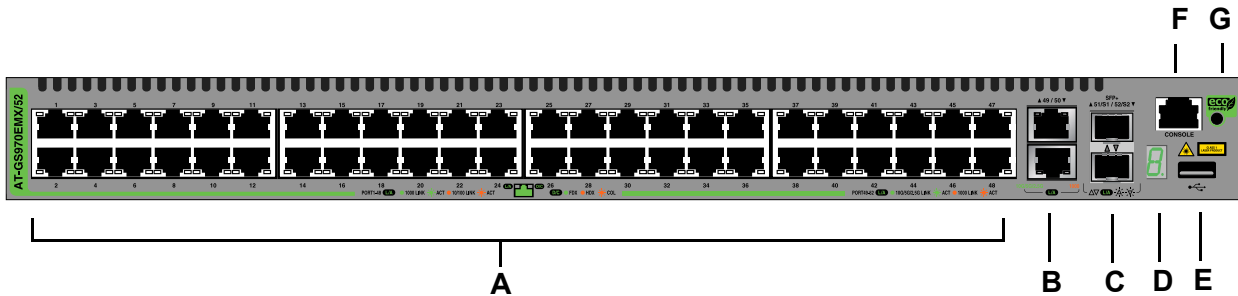

- | | |
|--|---|
| <p>A. Forty-eight 10/100/1000Mbps Copper Ports</p> <p>B. Two 1/2.5/5/10Gbps Multi-Gigabit Copper Ports</p> <p>C. Two 1/10Gbps SFP+ Transceiver Ports</p> <p>D. Switch ID LED</p> | <p>E. One USB Flash Drive Port</p> <p>F. One Local Management Console Port</p> <p>G. eco-friendly Button</p> |
|--|---|

Figure 4. Front Panel of the GS970EMX/52 Switch

Figure 5 illustrates the back panels.

GS970EMX/10 Switch



GS970EMX/20 and GS970EMX/28 Switches



GS970EMX/52 Switch



Figure 5. Back Panels

Note

The GS970EMX/10, GS970EMX/20, and GS970EMX/28 Switches are fanless. The GS970EMX/52 Switch has a single fan inside the back panel. Its ventilation direction is from front to back, with the fan drawing air out of the device.

Features

10/100/1000Mbps Copper Ports

The basic features of the 10/100/1000Mbps copper ports are listed here:

- 10Base-T, 100Base-TX, and 1000Base-T compliant
- IEEE 802.3u Auto-Negotiation compliant
- Auto-MDI/MDIX
- 100 meters (328 feet) maximum operating distance
- IEEE 802.3x flow control in 10/100Base-TX full-duplex mode
- IEEE 802.3x backpressure in 10/100Base-TX half-duplex mode
- Speed/activity LEDs
- Jumbo frames up to 12288 bytes
- RJ-45 connectors

1/2.5/5/10Gbps Multi-Gigabit Copper Ports

The basic features of the 1/2.5/5/10Gbps Multi-Gigabit copper ports are listed here:

- 1000Base-T, 2.5GBase-T, 5GBase-T, and 10GBase-T compliant
- IEEE 802.3bz for 2.5GBase-T and 5GBase-T
- Auto-Negotiation for speed
- 100 meters (328 feet) maximum operating distance per port
- Full-duplex mode only
- Speed/activity LEDs
- RJ-45 connectors

1/10Gbps SFP+ Ports

The SFP+ ports support the following types of 1Gbps SFP and 10Gbps SFP+ transceivers:

- 1Gbps SFP 1000Base-SX/LX transceivers
- 1Gbps SFP 1000Base-LX single-port BiDi transceivers
- 1Gbps SFP 1000Base-ZX transceivers
- 10Gbps SFP+ 10GBase-SR/LR fiber optic transceivers
- 10Gbps SFP+ 1-meter SP10TW1 and 3-meter SP10TW3 direct connect twinax cables with SFP+ transceiver-style connectors
- 10Gbps SFP+ single-port BiDi transceivers
- SP10TM 1/2.5/5/10Gbps copper transceiver

Note

The SFP+ ports do not support 100Mbps 100Base-FX transceivers.

Note

The ports support full-duplex mode only.

Note

SFP and SFP+ transceivers are sold separately. Refer to the product's data sheet on the Allied Telesis website for a list of supported transceivers.

Note

The switches do not support the 7-meter SP10TW7 direct connect twinax cable.

Port and System LEDs

Here are the port and system LEDs:

- Speed/activity and duplex mode LEDs for the 10/100/1000Mbps copper ports
- Speed/activity LEDs for the 1/2.5/5/10Gbps Multi-Gigabit copper ports
- Speed/activity LEDs for the SFP+ ports
- Switch ID number LED

Note

Refer to "Port LEDs" on page 31.

Installation Options

Here are the installation options for the switches:

- Desk or tabletop
- Standard 19-inch equipment rack
- Wood or concrete wall

MAC Address Table

Here are the basic features of the MAC address tables in the switches:

- Storage capacity of 16,384 dynamic entries
- Storage capacity of 256 static entries
- Automatic learning and aging

Management Software and Interfaces

Here are the management software and interfaces:

- AlliedWare Plus Management Software
- Local management through the Console port
- Remote Telnet and Secure Shell management

- Remote HTTP and HTTPS web browser management
- Command line interface
- Autonomous Management Framework
- Vista Manager EX
- SNMPv1, v2c, and v3

Energy Savings Here are energy saving features:

- eco-friendly button for turning on and off the port LEDs
- IEEE 802.3az Energy-Efficient Ethernet (EEE)

10/100/1000Mbps Copper Ports

Table 1 lists the specifications of the 10/100/1000Mbps copper ports.

Table 1. Specifications of the 10/100/1000Mbps Copper Ports

Feature	Description
Speeds	Port speeds are listed here: <ul style="list-style-type: none"> - 10Mbps (IEEE802.3 10Base-T) - 100Mbps (IEEE802.3u 100Base-TX) - 1Gbps (IEEE802.3ab 1000Base-T) Speeds are set manually or with IEEE 802.3u Auto-Negotiation.
Duplex modes	Duplex modes are listed here: <ul style="list-style-type: none"> - Half- or full-duplex mode at 10/100Mbps - Full-duplex mode only at 1000Mbps Duplex modes are set manually or with IEEE 802.3u Auto-Negotiation. <p>Speed and duplex mode settings of copper ports can be set independently of each other. For instance, ports can be configured such that their speeds are set manually while their duplex modes are set through Auto-Negotiation.</p>
Wiring	Auto-MDI/MDIX at 10/100/1000Mbps (IEEE 802.3ab-compliant)
Maximum Distance	100 meters (328 feet)
Cable	Cable requirements are listed here: <ul style="list-style-type: none"> - 10/100Mbps - Standard TIA/EIA 568-B-compliant Category 3 unshielded cable or better. - 1Gbps - Standard TIA/EIA 568-B-compliant Category 5 or Category 5e unshielded cable or better.

Table 1. Specifications of the 10/100/1000Mbps Copper Ports (Continued)

Feature	Description
Additional Features	Additional features are listed here: <ul style="list-style-type: none"> - 8-pin RJ-45 connectors - Backpressure flow control supported at half-duplex mode - Non-blocking, wire speed supported at all speeds. - Jumbo frames up to 12288 bytes - 2MB packet buffer

For port pinouts, refer to “RJ-45 Copper Port Pinouts” on page 173.

Note

Copper ports must be set to Auto-Negotiation, the default, to function at 1000Mbps. The network devices must be IEEE 802.3u compliant.

Note

Copper ports that are connected to devices that do not support Auto-Negotiation should not use Auto-Negotiation to set speed and duplex mode. Otherwise, a speed or duplex mode mismatch might occur between the devices, resulting in reduced performance. You should set speed and duplex mode manually on copper ports that are connected to devices that do not support Auto-Negotiation.

1/2.5/5/10Gbps Multi-Gigabit Copper Ports

The GS970EMX/10 Switch has one Multi-Gigabit copper port. The GS970EMX/20, GS970EMX/28, and GS970EMX/52 Switches have two Multi-Gigabit copper ports. Table 2 lists the port specifications.

Table 2. Specifications of the 1/2.5/5/10Gbps Multi-Gigabit Copper Ports

Specification	Description
Port Speed	<p>Here are the supported speeds:</p> <ul style="list-style-type: none"> - 1Gbps (IEEE802.3ab) - 2.5Gbps (IEEE 802.3bz) - 5Gbps (IEEE 802.3bz) - 10Gbps (IEEE 802.3an) <p>You can set port speed with Auto-Negotiation or manually. Guidelines are given here:</p> <ul style="list-style-type: none"> - 1Gbps and 10Gbps can be set either manually or with Auto-Negotiation. - 2.5Gbps and 5Gbps must be set with Auto-Negotiation. - The default setting is Auto-Negotiation.
Duplex Mode	Full-duplex only
Maximum Distance	100 meters (328 feet)
Connector	8-pin RJ-45
Cable Requirements	<ul style="list-style-type: none"> - 1/2.5/5Gbps - Standard TIA/EIA 568-A-compliant Category 5 or TIA/EIA 568-B-compliant Enhanced Category 5 (Cat 5e) unshielded cabling. - 10Gbps -Standard TIA/EIA 568-C-compliant Category 6a unshielded cabling.

Table 2. Specifications of the 1/2.5/5/10Gbps Multi-Gigabit Copper Ports

Specification	Description
Additional Features	Additional features are listed here: <ul style="list-style-type: none"><li data-bbox="915 369 1243 401">- 8-pin RJ-45 connectors<li data-bbox="915 411 1446 478">- Non-blocking, wire speed supported at all speeds<li data-bbox="915 489 1463 556">- Supports up to 12KB jumbo frames at 1/5/10Gbps<li data-bbox="915 567 1430 634">- Supports up to 10KB jumbo frames at 2.5Gbps<li data-bbox="915 644 1179 676">- 2MB packet buffer

Note

Network devices connected to Multi-Gigabit ports must be IEEE 802.3u compliant.

SFP+ Ports

The GS970EMX/10 Switch has one SFP+ port. The GS970EMX/20, GS970EMX/28, and GS970EMX/52 Switches have two SFP+ ports. The ports support the following types of 1Gbps SFP and 10Gbps SFP+ transceivers:

- ❑ 1Gbps SFP 1000Base-SX/LX transceivers
- ❑ 1Gbps SFP 1000Base-LX single-port BiDi transceivers
- ❑ 1Gbps SFP 1000Base-ZX transceivers
- ❑ 10Gbps SFP+ 10GBase-SR/LR fiber optic transceivers
- ❑ 10Gbps SFP+ 1-meter SP10TW1 and 3-meter SP10TW3 direct connect twinax cables with SFP+ transceiver-style connectors
- ❑ 10Gbps SFP+ single-port BiDi transceivers
- ❑ SP10TM 1/2.5/5/10Gbps copper port transceiver

You can use the ports to connect switches to other network devices over large distances, build a high-speed backbone network between network devices, or connect high-speed devices, such as servers, to your network.

Note

The SFP+ ports do not support 100Mbps 100Base-FX transceivers.

Note

The ports support full-duplex mode only.

Note

SFP and SFP+ transceivers are sold separately. Refer to the product's data sheet for a list of supported transceivers.

Note

The switches do not support the 7-meter SFP+ SP10TW7 direct connect twinax cable.

Port LEDs

This section describes the LEDs on the copper, Multi-Gigabit, and SFP+ port.

10/100/1000Mbps Copper Port LEDs

The 10/100/1000Mbps copper ports have two LEDs that display the following information:

- ❑ Speed/activity
- ❑ Duplex mode

The LEDs are identified in Figure 6.

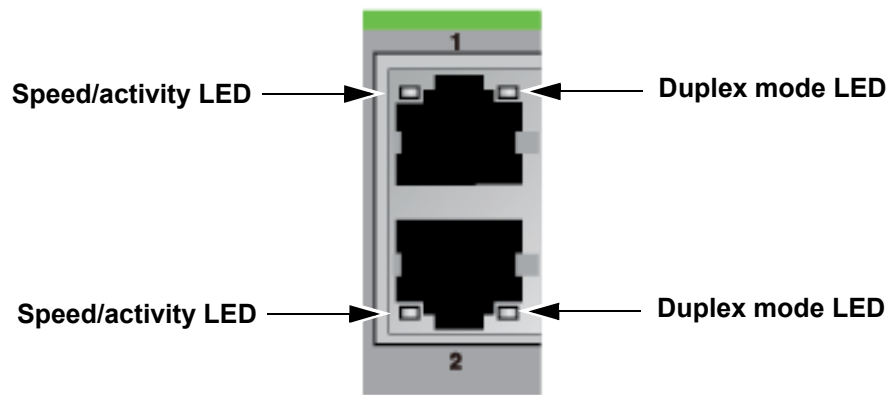

Figure 6. Speed/Activity and Duplex Mode LEDs for the 10/100/1000Mbps Copper Ports

Table 3 and Table 4 on page 32 define the LEDs.

Table 3. Speed/Activity LEDs for the 10/100/1000Mbps Copper Ports

State	Description
Solid Green	The port has established a link at 1Gbps to a network device.
Flashing Green	The port is transmitting or receiving network packets at 1Gbps.
Solid Amber	The port has established a link at 10 or 100Mbps to a network device.
Flashing Amber	The port is transmitting or receiving network packets at 10 or 100Mbps.

Table 3. Speed/Activity LEDs for the 10/100/1000Mbps Copper Ports

State	Description
Off	Possible causes of this state are listed here: <ul style="list-style-type: none"> - The port has not established a link with another network device. - The LEDs are turned off. To turn on the LEDs, use the eco-friendly button.

Table 4 describes the duplex mode LEDs for the 10/100/1000Mbps copper ports.

Table 4. Duplex Mode LEDs for the 10/100/1000Mbps Copper Ports

State	Description
Solid Green	The port is operating in full duplex mode.
Solid Amber	The port is operating in half duplex mode.
Flashing Amber	The port is operating in half duplex mode, with collisions.
Off	Possible causes of this state are listed here: <ul style="list-style-type: none"> - The port has not established a link with another network device. - The LEDs are turned off. To turn on the LEDs, use the eco-friendly button.

1/2.5/5/10Gbps Multi-Gigabit Copper Port LEDs

The 1/2.5/5/10Gbps Multi-Gigabit copper ports have two LEDs that display speed/activity information. Refer to Figure 7.

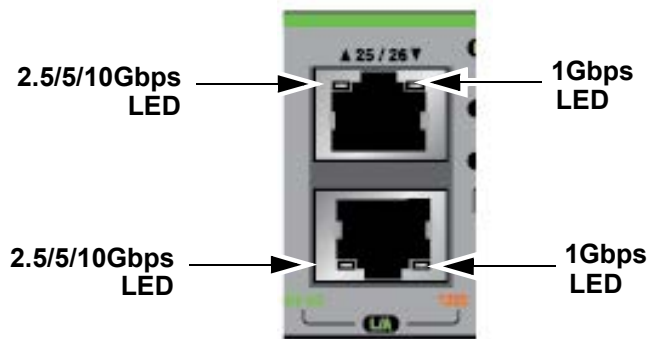
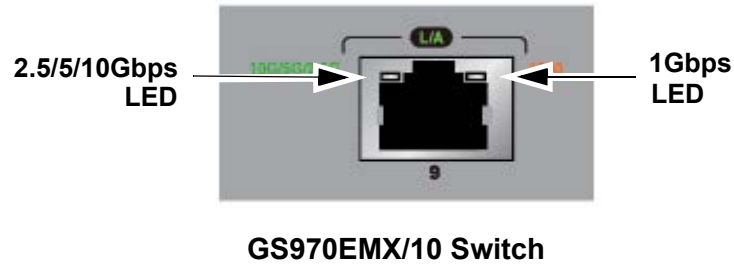

**GS970EMX/20, GS970EMX/28, and
GS970EMX/52 Switches**

Figure 7. Speed/Activity LEDs for the 1/2.5/5/10Gbps Multi-Gigabit Copper Ports

Table 5 describes the LEDs.

Table 5. Speed/Activity LEDs for the 1/2.5/5/10Gbps Multi-Gigabit Copper Ports

State	Description
Solid Green (left LED)	The port has established a link at 2.5Gbps, 5Gbps, or 10Gbps to a network device.
Flashing Green (left LED)	The port is transmitting or receiving data at 2.5Gbps, 5Gbps, or 10Gbps.
Solid Amber (right LED)	The port has established a link at 1Gbps to a network device.
Flashing Amber (right LED)	The port is transmitting or receiving data at 1Gbps.

Table 5. Speed/Activity LEDs for the 1/2.5/5/10Gbps Multi-Gigabit Copper Ports (Continued)

State	Description
Off	Possible causes of this state are listed here: <ul style="list-style-type: none"> - The port has not established a link with another network device. - The LEDs are turned off. To turn on the LEDs, use the eco-friendly button.

1/10Gbps SFP+ Port LEDs

The 1/10Gbps SFP+ ports have one LED that displays speed/activity information. Refer to Figure 8.



GS970EMX/10 Switch



GS970EMX/20 and GS970EMX/28 Switches



GS970EMX/52 Switch

Figure 8. Speed/Activity LEDs for the 1/10Gbps SFP+ Ports

Table 6 describes the LED.

Table 6. Speed/Activity LEDs for the 1/10Gbps SFP+ Ports

State	Description
Solid Amber	The port has established a link at 1Gbps to a network device.
Flashing Amber	The port is transmitting or receiving data at 1Gbps.
Solid Green	The port has established a link at 10Gbps to a network device.
Flashing Green	The port is transmitting or receiving data at 10Gbps.
Off	Possible causes of this state are listed here: <ul style="list-style-type: none"> - The port has not established a link with another network device. - The LEDs are turned off. To turn on the LEDs, use the eco-friendly button.

eco-friendly Button

You use the eco-friendly button on the front panel of the switch to toggle the port LEDs on and off. You can conserve electricity by turning off the LEDs when you are not monitoring the device. When the LEDs are turned off, the switch is operating in the low power eco-friendly mode. Turning off the port LEDs does not interfere with the network operations of the switch. When the switches are operating in a stack, pressing the eco-friendly button toggles the eco-friendly mode on all the stack switches.

You can also toggle the port LEDs on and off with the ECOFRIENDLY LED and NO ECOFRIENDLY LED commands in the Global Configuration mode in the command line interface of the AlliedWare Plus management software, as follows:

- ❑ ECOFRIENDLY LED command - Turns off the LEDs.
- ❑ NO ECOFRIENDLY LED command - Turns on the LEDs.

The AlliedWare Plus management software has a command that blinks all the port LEDs so that you can quickly identify a specific unit among the devices in an equipment rack. It is the FINDME command. The command works even if the port LEDs are turned off.

The Switch ID LED is always on. It displays different information depending on whether the port LEDs are on or off. When the port LEDs are on, the Switch ID LED displays the ID number of the switch in a VCStack. When the switch is operating in the low power mode with the port LEDs off, the Switch ID LED indicates whether the switch is the master or member switch of a VCStack. Refer to “Switch ID LED” on page 37.

Note

Before checking or troubleshooting network connections to the ports on the switch, you should always verify that the LEDs are on by pressing the eco-friendly button or issuing the NO ECOFRIENDLY LED command in the Global Configuration mode of the command line interface.

Switch ID LED

The Switch ID LED, shown in Figure 9, is for the VCStack feature for the GS970EMX/20, GS970EMX/28, and GS970EMX/52 Switches. You can manage up to four switches as a single unit. This simplifies network management and allows you to add redundancy to your network topology by distributing functions across multiple switches.



Figure 9. Switch ID LED

The LED displays different information depending on whether the low power eco-friendly mode is on or off. Refer to “eco-friendly Button” on page 36. Figure 10 lists the states of the LED when the eco-friendly mode is off and the port LEDs are on.

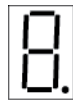

The switch is booting up.



The switch has detected a fault condition, such as overheating.

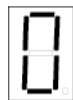

VCStack is disabled. The switch is a standalone unit.

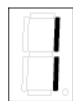

VCStack is enabled. The switch has an ID number in the range of 1 to 4.



Flashing dot in the lower right corner indicates the switch is accessing a USB flash drive.

2666

Figure 10. Switch ID LED with eco-friendly Mode Off (Port LEDs On)

Note

The GS970EMX/10 Switch does not support the VCStack feature. It operates as a standalone device with the Switch ID “0”.

Note

If the Switch ID LED displays “F” for a fault condition, use the SHOW SYSTEM ENVIRONMENT command in the command line interface of the AlliedWare Plus management software to identify the source of the problem.

Figure 11 illustrates the states of the LED when the eco-friendly mode is on and the port LEDs are off.



The switch is the master switch of a VCStack.



The switch is a standalone unit.



The switch is a member switch of a VCStack.

2667

Figure 11. Switch ID LED with eco-friendly Mode On (Port LEDs Off)

USB Port

You can use the USB port to store configuration files on flash drives to maintain a history of the switch's configurations, or to restore configuration files to the switch. You can also use the port and flash drives to quickly configure replacement units and update the AlliedWare Plus management software.

The port is USB 2.0 compatible.

Console Port

You use the Console port to configure the features and parameter settings of the switch with the command line interface in the AlliedWare Plus management software. This management is called local management because it is not conducted over your network. You have to be at the physical location of the switch. The Console port has these settings:

- Default baud rate: 9600 bps (Range is 9600 to 115200 bps)
- Data bits: 8
- Parity: None
- Stop bits: 1
- Flow control: None

Note

These settings are for a DEC VT100 or ANSI terminal, or an equivalent terminal emulation program.

Local management sessions require a management cable for connecting your computer or terminal to the Console port. Here are the cable guidelines:

- If your computer has an RS-232 port, you may use the management cable supplied with the switch. Refer to Figure 25 on page 72. The cable has RJ-45 and DB-9 connectors.
- If your computer has a USB port, you may need to purchase a USB-to-Serial converter that is compatible with its operating system. An example is the VT-Kit3 from Allied Telesis.

The Console port pinouts are provided in “RJ-45 Style Serial Console Port Pinouts” on page 174. For further information, refer to “Starting a Local Management Session” on page 112.

Power Supply and Power Savings Features

The switches have one internal power supply. The power supply is not field-replaceable. Refer to “Power Specifications” on page 169 for the input voltage ranges.



Warning

Power cord is used as a disconnection device. To de-energize equipment, disconnect the power cord. *⚡* E3

The switches support the following power savings features:

- ❑ The switch supports IEEE 802.3az Energy-Efficient Ethernet (EEE). EEE is an energy saving feature that reduces power consumption during periods of no data activity. The switch saves electricity by placing the Ethernet circuitry in a special sleep mode when all the ports are inactive. When data activity resumes, the circuitry automatically resumes normal operations.
- ❑ The switches include the eco-friendly mode for turning off port LEDs to save power. Refer to “eco-friendly Button” on page 36.

Chapter 2

Virtual Chassis Stacking

The sections in this chapter are listed here:

- “Overview” on page 44
- “Stacking Guidelines” on page 45
- “Stack Trunks” on page 46
- “Master and Member Switches” on page 54
- “Switch ID Numbers” on page 55
- “Feature Licenses” on page 56
- “Planning the Stack” on page 57
- “Specifying Ports in the Command Line Interface” on page 58
- “VCStack Worksheet” on page 60

Note

For more information on VCStack, refer to the *Stacking Introduction and Stacking Commands* chapters in the *Software Reference for GS970EMX Series Switches, AlliedWare Plus Operating System* or the *Virtual Chassis Stacking Feature Overview and Configuration Guide* on the Allied Telesis website.

Overview

The Virtual Chassis Stacking (VCStack) feature allows you connect up to four GS970EMX/20 , GS970EMX/28, and GS970EMX/52 Switches into a virtual stack so that they function as a single networking unit. Here are some of the VCStack benefits:

- ❑ Simplifies management - You can manage the devices as a single unit. Your local and remote management sessions automatically give you management access to all the devices.
- ❑ Reduces IP addresses - A stack requires only one IP address for remote management access, reducing the number of IP addresses you have to assign to network devices. The one address gives you management access to all the stack units.
- ❑ Adds network redundancy - You can add redundancy to your network topology by distributing functions across multiple switches. For instance, static port trunks on standalone switches have to consist of ports from the same switch while static trunks in stacks can have ports from different switches.
- ❑ Reduces protocol requirements - Building a stack might eliminate the need to configure some protocols, such as the Virtual Router Redundancy Protocol or Spanning Tree Protocol.

Stacking Guidelines

Here are general VCStack guidelines:

- ❑ A stack can have up to four GS970EMX Switches.
- ❑ The switches can be the same or different GS970EMX Switch models.
- ❑ VCStack comes standard with the AlliedWare Plus management software. No additional software or licenses are required.
- ❑ The VCStack default setting on the switch is enabled.
- ❑ Switches can belong to only one stack at a time.
- ❑ Do not configure switch features, such as virtual LANs or routing protocols, before building the stack. Switches might discard the configuration settings when the stack is powered on for the first time.
- ❑ If you purchased optional feature licenses, refer to their installation directions to determine whether you should install them before or after building the stack. Refer to “Feature Licenses” on page 56.
- ❑ Any GS970EMX Switch can be the master switch of the stack.
- ❑ Stacks cannot contain switches from other series, such as x930 or x950 Switches.
- ❑ The switches must have the same version of AlliedWare Plus management software.

Note

The GS970EMX/10 Switch does not support VCStack.

Stack Trunks

The switches of a stack are connected by a physical network link called the stack trunk. Consisting of two ports on each switch, stack trunks have these guidelines:

- ❑ You can use either the two Multi-Gigabit copper ports or the two SFP+ ports as the stack trunk. On the GS970EMX/20 Switch, the Multi-Gigabit copper ports are 17 and 18, and the SFP+ ports are 19/S1 and 20/S2. On the GS970EMX/28 Switch, the Multi-Gigabit copper ports are 25 and 26, and the SFP+ ports are 27/S1 and 28/S2. On the GS970EMX/52 Switch, the Multi-Gigabit copper ports are 49 and 50, and the SFP+ ports are 51/S1 and 52/S2.
- ❑ The default stack trunk ports are the SFP+ ports.
- ❑ A stack can have only one trunk.
- ❑ To use the Multi-Gigabit copper ports as the stack trunk, you first have to remove the SFP+ ports from the trunk and then add the Multi-Gigabit copper ports. This is explained in Chapter 10, “Building Stacks with Multi-Gigabit Copper Ports” on page 127.
- ❑ The trunk cannot contain both SFP+ ports and Multi-Gigabit copper ports.
- ❑ The trunk ports must be at their default settings.
- ❑ Allied Telesis recommends on stacks of three or more switches connecting the top and bottom switches together to form a loop in the trunk topology. This is illustrated in the following examples.
- ❑ You cannot view or change the parameter settings of trunk ports.

SFP+ Ports S1 and S2

Here are additional guidelines for the SFP+ ports S1 and S2 as the stack trunk:

- ❑ The SFP+ ports support 1Gbps and 10Gbps transceivers when used as regular Ethernet ports. For best performance, Allied Telesis recommends 10Gbps transceivers for the stack trunk.
- ❑ If the switches are physically adjacent to each other, such as in the same or adjacent equipment racks, you can use 1-meter SP10TW1 or 3-meter SP10TW3 10Gbps direct connect twinax cables for the trunk cables.

Note

The GS970EMX Switches do not support the 7-meter SP10TW7 cable.

- ❑ The fiber optic transceivers or direct attach cables for the trunk must be from Allied Telesis. For a list of supported transceivers, refer to the product’s data sheet on the Allied Telesis web site.

Figure 12 to Figure 14 on page 48 illustrate several cabling examples of the SFP+ ports S1 and S2 as the trunk for stacks of two, three, and four switches. As illustrated, the trunk cables can crossover to different SFP+ ports S1 and S2 on the switches or connect the same ports. The illustrations show the GS970EMX/28 Switch. The same rules apply to the GS970EMX/20 and GS970EMX/52 Switches.



Figure 12. Stack Trunks of SFP+ Ports S1 and S2 for Two Switches

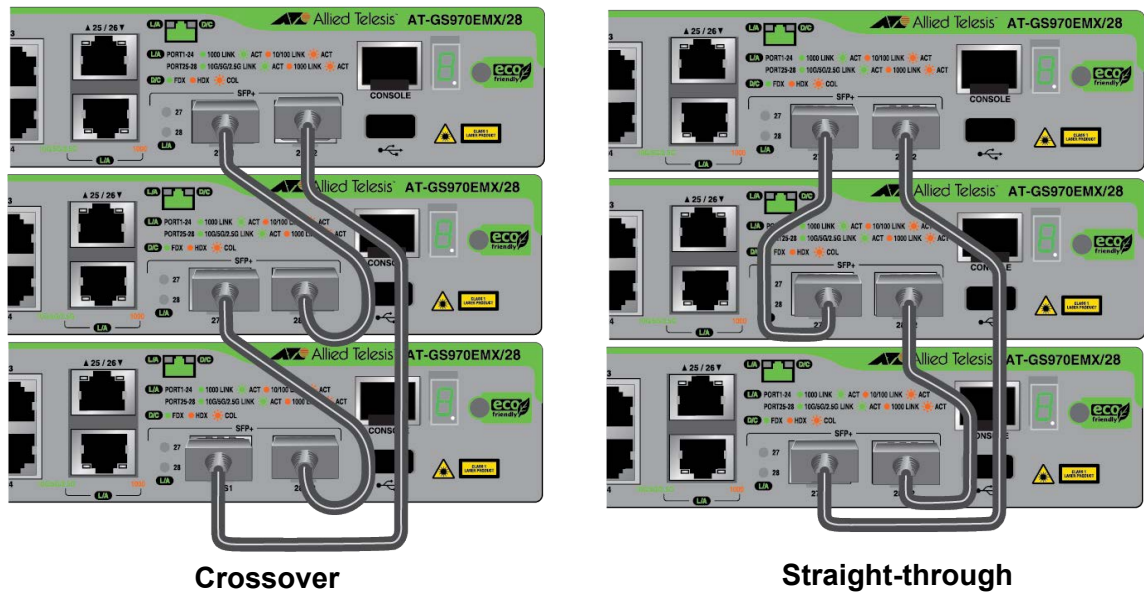

Figure 13. Stack Trunks of SFP+ Ports S1 and S2 for Three Switches

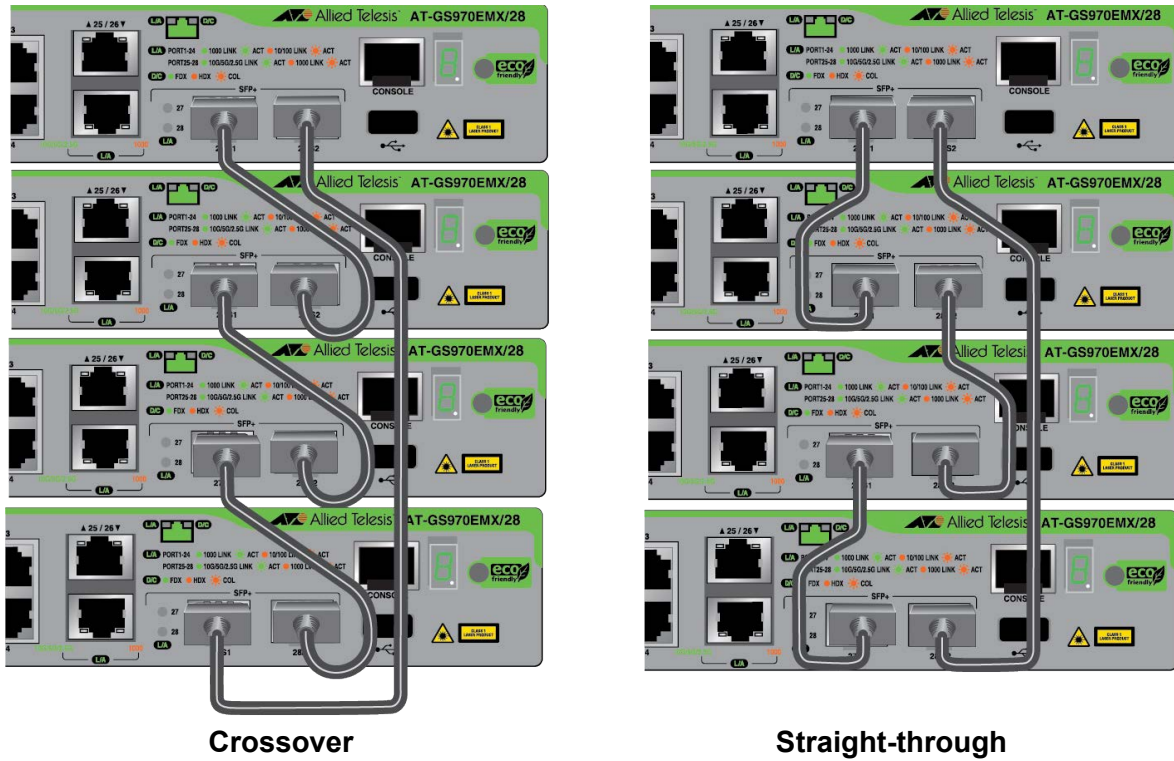

Figure 14. Stack Trunks of SFP+ Ports S1 and S2 for Four Switches

Stacks can have combinations of GS970EMX/20, GS970EMX/28, and GS970EMX/52 Switches. The stack in Figure 15 has two GS970EMX/20 Switches (top), one GS970EMX/28 Switch, and one GS970EMX/52 Switch (bottom).

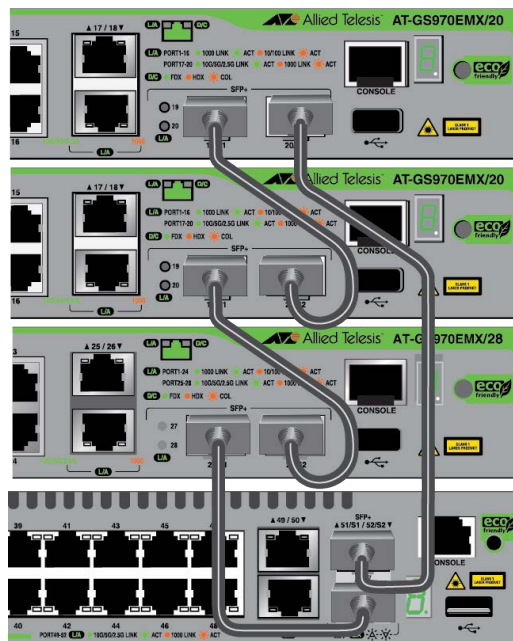

Figure 15. Mixed Stack of GS970EMX Switches

In the previous figures, the top and bottom switches are connected to form a loop topology in the trunk. This adds redundancy to the trunk by allowing the switches to maintain the stack even if a trunk link should fail.

The switches support the linear or chain configuration for the trunk, where the top and bottom switches are not linked together. Refer to Figure 16 for an example. Allied Telesis does not recommend this configuration because it does not provide redundancy should a trunk link fail.

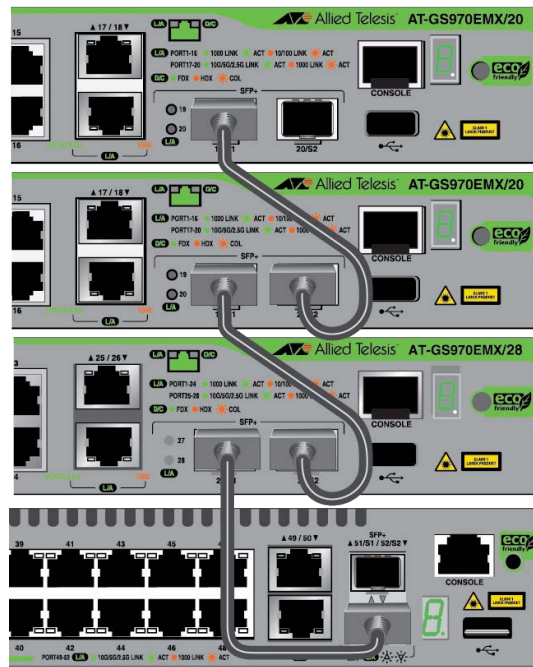
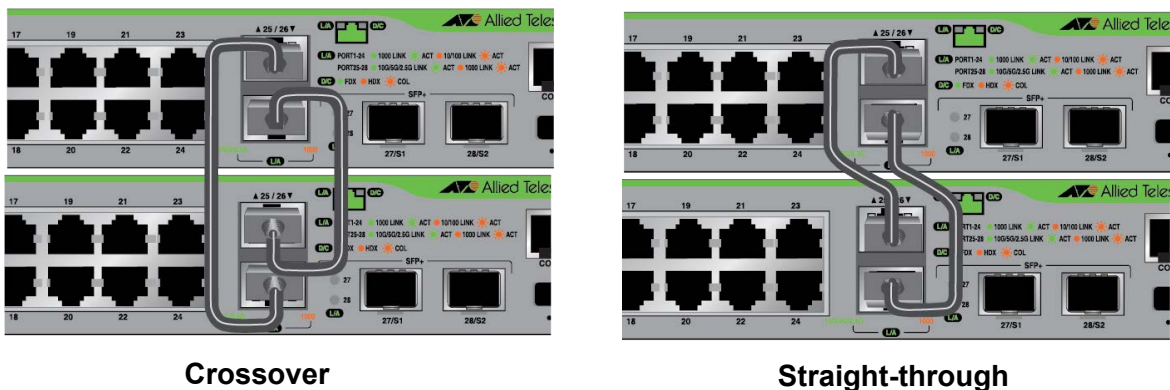

Figure 16. Chain Stack Trunk of SFP+ Ports S1 and S2

Multi-Gigabit Copper Ports

Figure 17 to Figure 19 on page 50 illustrate trunks of the two Multi-Gigabit copper ports. As with the SFP+ ports S1 and S2, the cables can crossover to different ports on the switches or connect the same ports. The illustrations show the GS970EMX/28 Switch. The same rules apply to the GS970EMX/20 and GS970EMX/52 Switches.



Crossover

Straight-through

Figure 17. Stack Trunks of Multi-Gigabit Copper Ports for Two Switches

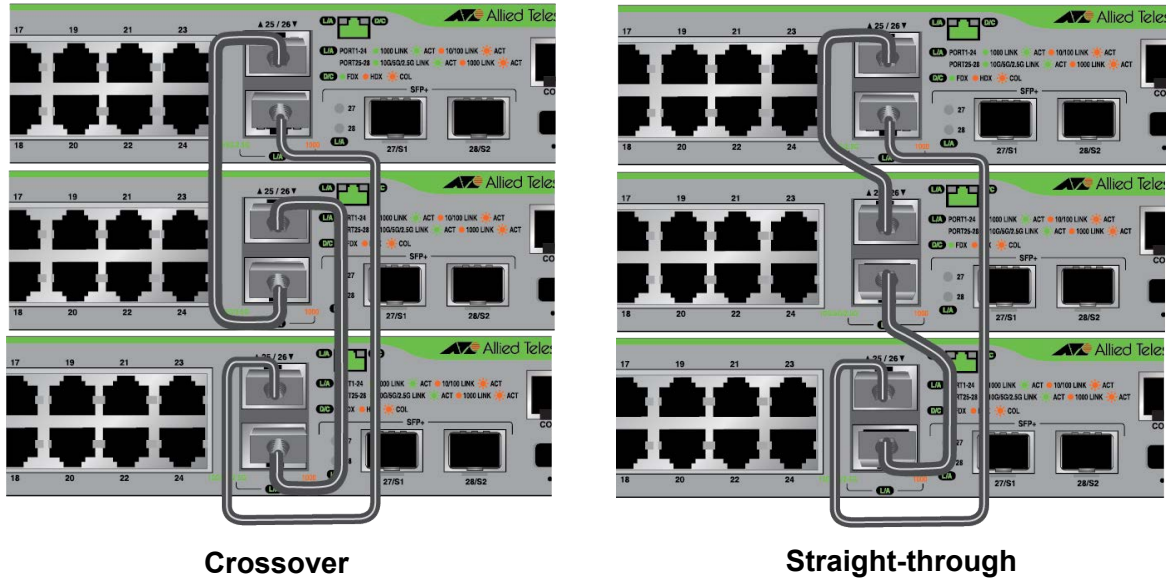

Figure 18. Stack Trunks of Multi-Gigabit Copper Ports for Three Switches

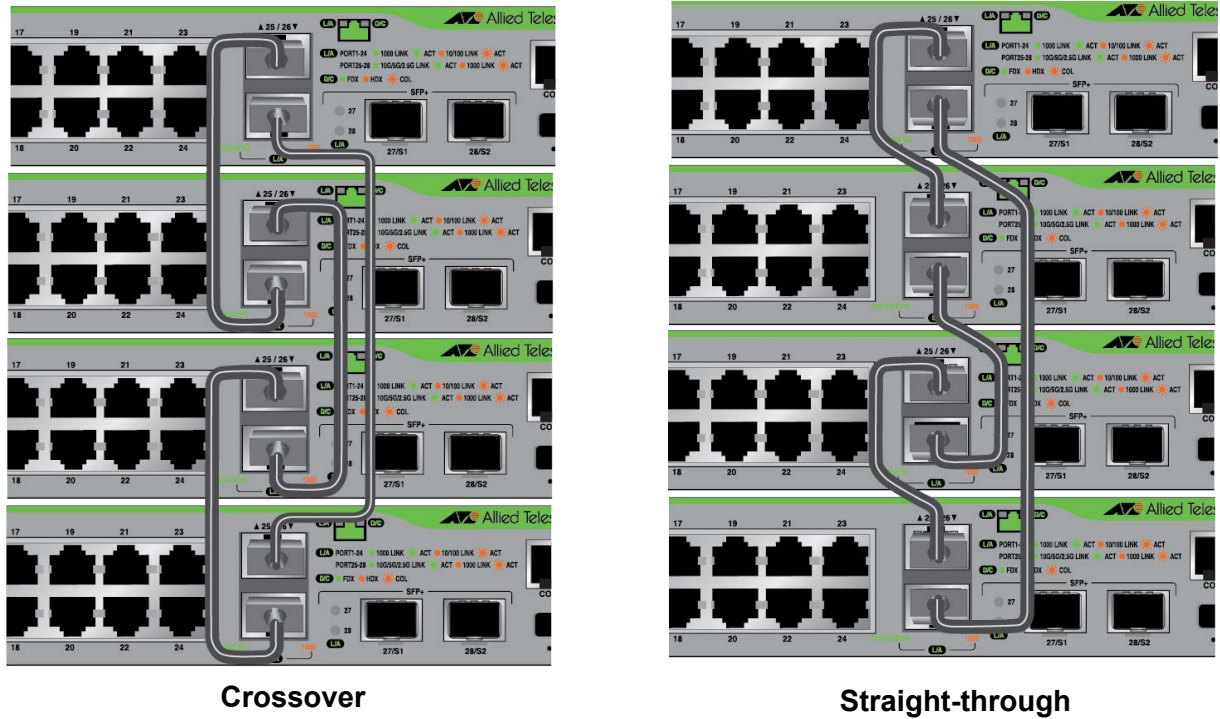

Figure 19. Stack Trunks of Multi-Gigabit Copper Ports for Four Switches

As with the SFP+ ports S1 and S2, the Multi-Gigabit copper ports support the chain topology, where ports on the top and bottom switches are unused. Refer to Figure 20 on page 51 for an example. This cable topology is not recommended because it does not provide trunk link redundancy.

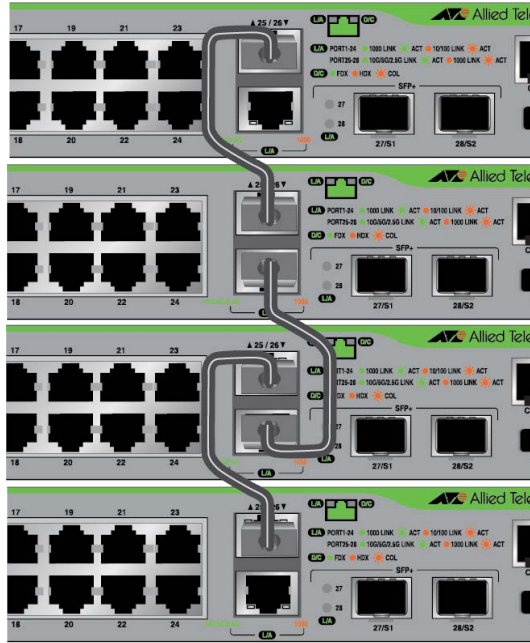

Figure 20. Chain Stack Trunk of Multi-Gigabit Copper Ports

Unsupported Trunks

The following examples illustrate unsupported trunks:

- ❑ Trunks cannot have both Multi-Gigabit copper ports and SFP+ ports S1 and S2. Refer to Figure 21.

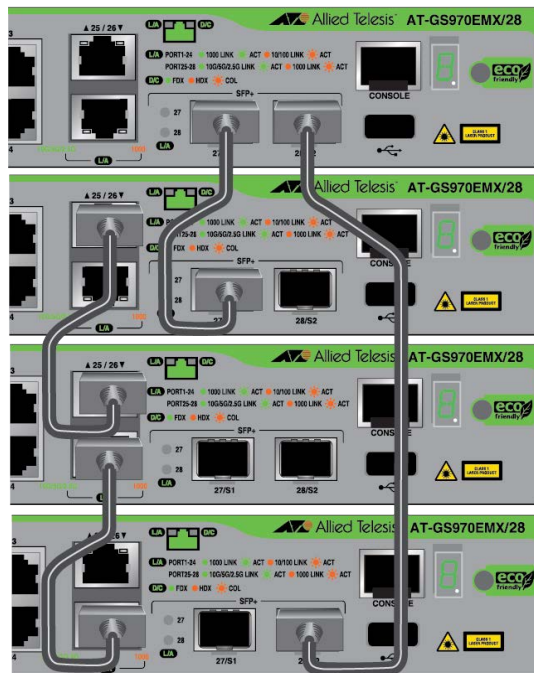

Figure 21. Unsupported Trunk of Multi-Gigabit Copper Ports and SFP+ Ports S1 and S2

- ❑ The cables of a stack trunk of the SFP+ ports S1 and S2 can be either fiber optic or direct attach cables, but not both. The trunk in Figure 22 is unsupported because it has both fiber optic and direct attach cables.

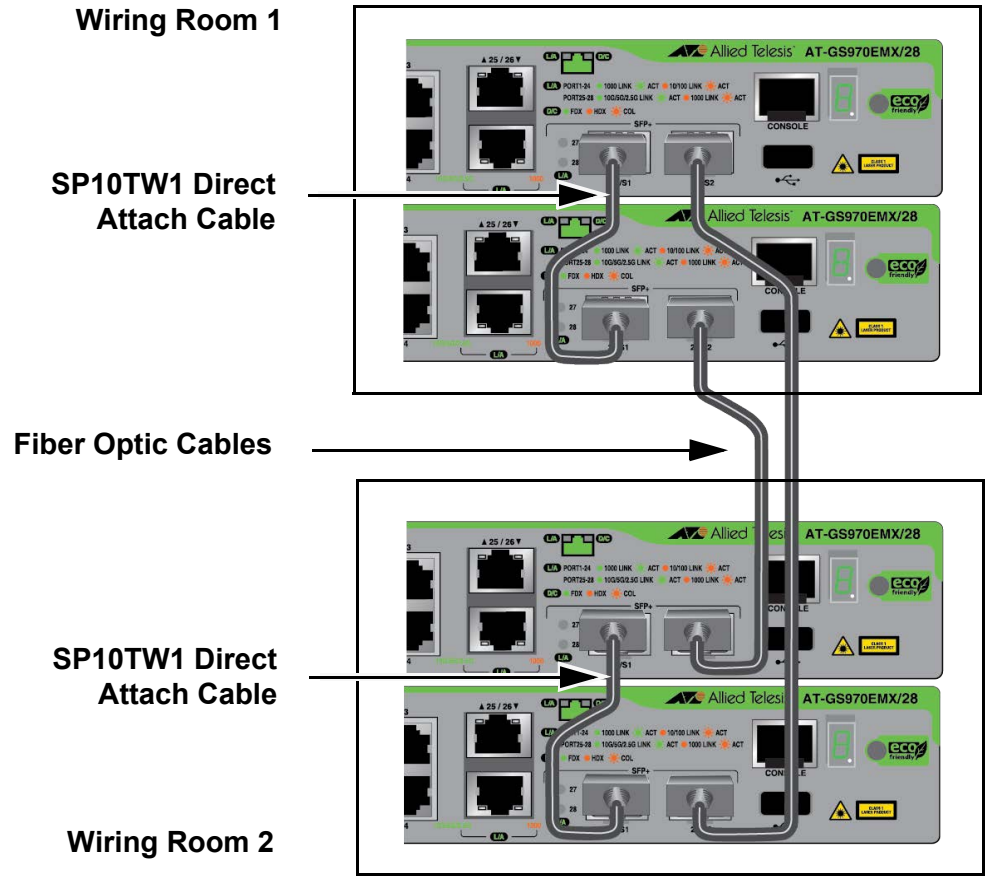

Figure 22. Unsupported Trunk of SFP+ Ports S1 and S2 with Mixed Cables

- ❑ Trunk links must be direct connections between trunk ports. There cannot be any network devices, such as media converters, routers, or other Ethernet switches, between trunk ports. The trunk in Figure 23 on page 53 is unsupported because the trunk ports are connected to a media converter.

Building 1



Media Converter

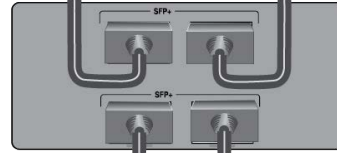

Building 2



Figure 23. Unsupported Trunk with a Network Device Between Trunk Ports

Master and Member Switches

Stacks have a master switch. It coordinates and monitors stack operations, and assigns switch ID numbers during the initial formation of the stack and when new switches are added. The other switches of the stack are referred to as member switches. Stacks of GS970EMX Switches can have one master switch and up to three member switches. Member switches can become the master switch if the active master switch stops managing the stack.

How you power on the switches of the stack determines how they select the master switch. You can power them on simultaneously or sequentially.

When you power on or reset all the switches of the stack simultaneously, they select the master switch based on these values:

- Stack priority numbers
- MAC addresses

The stack priority number is an adjustable value from 0 to 255, where the lower the number, the higher the priority. The switch with the lowest priority number (highest priority) becomes the master switch of a stack. The default priority value is 128.

If the switches have the same priority values, they compare their MAC addresses to select the master switch. As with the priority value, the lower the MAC address, the higher the priority. The switch with the lowest MAC address becomes the master switch.

The other method for powering on the switches of the stack is one at a time or sequentially. Here, the first switch powered on becomes the master switch. It remains the master switch even after all switches are powered on and the stack is operational.

Depending on how you power on the stack, it is possible for a different switch to become the master switch. However, this does not change the ID numbers or configurations of the switches, or how you manage the stack.

Switch ID Numbers

Each switch in the stack must have an ID number. The range is 1 to 4. The default is 1. The ID numbers are displayed on the ID LEDs on the front panels of the units. The ID numbers have these functions:

- ❑ You use the numbers with the PORT parameter to identify the switches when you manage them with the AlliedWare Plus management software. Refer to “Specifying Ports in the Command Line Interface” on page 58.
- ❑ The ID numbers and PORT parameter are stored in the stack configuration file to identify the switches and their parameter settings.

Here are three ways to assign switch ID numbers.

- ❑ You can assign the numbers yourself during the initial power-on of the stack by powering on the devices sequentially. The first switch powered on is assigned ID number 1, the second switch ID 2, and so on.
- ❑ You can have the switches assign the ID numbers automatically during the first power-on of the stack by powering on the switches simultaneously. The switches use their priority numbers and MAC addresses to assign ID numbers.
- ❑ You can use the STACK RENUMBER command.

Note

Switches retain their ID numbers even when powered off or rebooted.



Caution

You should not change the ID numbers of switches after configuring their parameter settings. Otherwise, the master switch might assign parameter settings to the wrong devices when you reset or power cycle the stack. *See* E79

The switches do not use their ID numbers to select the master switch. As explained in “Master and Member Switches” on page 54, the switches use their priority numbers and MAC addresses to select the master switch. Consequently, the master switch can have any ID number.

Feature Licenses

GS970EMX Switches come with the AlliedWare Plus management software and a set of features that are available as soon as you install the devices. The switches might have additional features that are unlocked with feature licenses from Allied Telesis. Refer to the product's data sheet on the Allied Telesis website for a list of feature licenses. Here are feature license guidelines:

- ❑ VCStack is part of the base features of GS970EMX Switches. It does not require a feature license.
- ❑ Depending on the feature license, you might have to order one license for each switch or one license for the whole stack.
- ❑ Some feature licenses might have to be installed while the switches are functioning as standalone devices.
- ❑ Some feature licenses might not be supported on VCStack.
- ❑ Switches might be able to form a stack even if they have different feature licenses. However, the features might only be available on those switches with licenses. VCStack generates a warning message if it detects that the switches do not have the same licenses.

Refer to the product's data sheet and the *Software Reference for GS970EMX Series Switches, AlliedWare Operating System* for more details.

Planning the Stack

Here are questions to answer before building the stack:

- How many switches will be in the stack? Stacks can have one master switch and up to three member switches.
- Will you use the SFP+ ports or Multi-Gigabit copper ports for the stack trunk? Refer to “Stack Trunks” on page 46.
- If the SFP+ ports will be the trunk ports, have you purchased the transceivers? Refer to the product’s data sheet on the Allied Telesis website for a list of supported transceivers.
- Have you filled out the worksheet in “VCStack Worksheet” on page 60?
- Have you connected network cables to the ports on the switches? If so, you should disconnect them before configuring switches for stacking.

Note

Cabling the trunk ports before activating and configuring the VCStack feature may result in loops in your network topology, which can cause poor network performance.

- How will you initially power on the switches of the stack? Will you power them on sequentially so as to select the master switch yourself, or simultaneously so that they select the master switch, automatically? Refer to “Master and Member Switches” on page 54.
- If you plan to power on the switches sequentially, have you determined the order in which you will power them on? This will determine their switch ID numbers and the initial assignment of the master switch. Refer to “Switch ID Numbers” on page 55.

Specifying Ports in the Command Line Interface

The ports on the switches of the stack are specified in the AlliedWare Plus command line interface with the PORT parameter. The format of the parameter is shown in Figure 24.

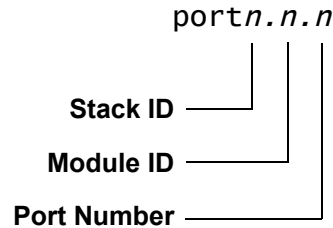

Figure 24. PORT Parameter in the Command Line Interface

The three parts of the PORT parameter are described in Table 7.

Table 7. PORT Parameter Format

Number	Description
Stack ID	Designates the switch’s unique ID number. This number identifies the switch in the stack. The range is 1 to 4 for GS970EMX Switches. The switches display their ID numbers on their Switch ID LEDs and in the SHOW STACK command in the command line interface. You may specify only one ID number in the PORT parameter.
Module ID	Designates the module number of a port. This value is always “0” for GS970EMX Switches because they do not support modules.
Port Number	Designates a copper or SFP+ port number.

This example of the PORT parameter uses the INTERFACE command to enter the Port Interface mode for ports 15 and 17 on a switch with the ID number 1:

```
awplus> enable
awplus# configure terminal
awplus(config)# interface port1.0.15,port1.0.17
```

This example enters the Port Interface mode for ports 1 and 2 on a switch with the ID number 3:

```
awplus> enable
awplus# configure terminal
awplus(config)# interface port3.0.1-port3.0.2
```

For instructions on the AlliedWare Plus command line interface and the PORT parameter, refer to the *Software Reference for GS970EMX Series Switches, AlliedWare Operating System*.

VCStack Worksheet

The worksheet in Table 8 is provided to assist you in building and maintaining a stack.

Table 8. VCStack Worksheet

Switch	Model/ Location	Switch ID	Prior- ity	Firmware Version Number ¹	Trunk Ports: SFP+ or Multi- Gigabit Copper	Transceivers in SFP+ Ports
Master						
Member						
Member						
Member						
Member						
Member						

1. AlliedWare Plus version number.

The worksheet columns are described in Table 9.

Table 9. Stacking Worksheet Columns

Column	Description
Model/Location	Use this column to record the model names and physical locations of the switches, such as their buildings or equipment rooms. The information can be useful in identifying and locating switches.

Table 9. Stacking Worksheet Columns (Continued)

Column	Description
Switch ID	<p>The switches in the stack must have unique ID numbers, in the range of 1 to 4. You use the numbers to identify and configure the switches in the AlliedWare Plus software. The switches display their ID numbers on the ID LEDs on the front panels. Refer to “Specifying Ports in the Command Line Interface” on page 58. Allied Telesis recommends deciding on their ID assignments before beginning the configuration procedures. The master switch can have any ID number, but the stack can be easier to manage if you assign it the ID 1.</p>
Priority	<p>Switches use priority values to select the master switch of the stack when they are powered on or reset, simultaneously. The range of 0 to 255. The default value is 128. The lower the value, the higher the priority. The switch with the lowest priority number becomes the master switch.</p> <p>If switches have the same priority number, they select the master by comparing their MAC addresses. Again, as with priority numbers, the lower the MAC address, the higher the priority.</p> <p>Switches do not use the priority values or MAC addresses to select the master switch when they are powered on sequentially. In this situation, the first switch powered on becomes the master switch, regardless of its priority number or MAC address.</p> <p>Allied Telesis recommends setting each switch’s priority value to match its ID value. This can protect the stack’s configuration if you later add more switches to an existing stack. It can also make it possible to know the order in which switches assume the master role if the primary master fails or is powered off.</p>

Table 9. Stacking Worksheet Columns (Continued)

Column	Description
Firmware Version Number	Use this column to record the version numbers of the AlliedWare Plus software on the switches. Switches might not form the stack if they have different versions. You should update switches that have different versions to the most recent release before building the stack. Refer to “Displaying the Hardware Status and AlliedWare Plus Version Number” on page 115
Trunk Ports - SFP+ or Multi-Gigabit Copper	Use this column to enter the trunk ports. The trunk ports can be either of the following: <ul style="list-style-type: none"> - SFP+ ports S1 and S2. These are the default trunk ports. - Multi-Gigabit copper ports
Transceivers in SFP+ Ports	Use this column to record the model names of the transceivers in the SFP+ ports.

Table 10 is an example of a worksheet for a stack of two GS970EMX/20 Switches, one GS970EMX/28 Switch, and one GS970EMX/52 Switch. The switches use the SFP+ ports for the stack trunk. The switches are in the same equipment rack, making it possible to use 1-meter SP10TW1 and 3-meter SP10TW3 direct attach cables for the trunk. Fiber optic transceivers can be used in stacks when the switches are further apart.

Table 10. Stack Worksheet Example with SFP+ Ports as Stack Trunk

Switch	Switch/ Location	Switch ID	Prior-ity	Firmware Version Number	Trunk Ports: SFP+ or Multi-Gigabit Copper	Transceivers in SFP+ Ports
Master	GS970EMX/20 Bldg 2A, rm:304	1	1	v5.5.0-1	19/S1, 20/S2	S1: SP10TW1 S2: SP10TW3
Member	GS970EMX/20 Bldg 2A, rm:304	2	2	v5.5.0-1	19/S1, 20/S2	S1: SP10TW1 S2: SP10TW1
Member	GS970EMX/28 Bldg 2A, rm:304	3	3	v5.5.0-1	27/S1, 28/S2	S1: SP10TW1 S2: SP10TW1
Member	GS970EMX/52 Bldg 2A, rm:304	4	4	v5.5.0-1	51/S1, 52/S2	S1: SP10TW1 S2: SP10TW3

The worksheet in Table 11 documents a stack of one GS970EMX/20 Switch, one GS970EMX/28 Switch, and two GS970EMX/52 Switches. They use the Multi-Gigabit copper ports for the stack trunk. The SFP+ ports are used for other functions, such as attaching high-speed devices to the network with fiber optic cables over long or short distances.

Table 11. Stack Worksheet Example with Multi-Gigabit Copper Ports as Stack Trunk

Switch	Switch/ Location	Switch ID	Prior- ity	Firmware Version Number	Trunk Ports: SFP+ or Multi- Gigabit Copper	Transceivers in SFP+ Ports
Master	GS970EMX/20 Bldg 2A, rm:304	1	1	v5.5.0-1	Multi-Gigabit 17, 18	19/S1: SP10SR 20/S2:empty
Member	GS970EMX/28 Bldg 2A, rm:304	2	2	v5.5.0-1	Multi-Gigabit 25, 26	27/S1: SP10LR 28/S2: SP10SR
Member	GS970EMX/52 Bldg 2A, rm:402	3	3	v5.5.0-1	Multi-Gigabit 49, 50	51/S1:empty 52/S2: SPLX10
Member	GS970EMX/52 Bldg 2A, rm:404	4	4	v5.5.0-1	Multi-Gigabit 49, 50	51/S1: empty 52/S2: SP10SR

Chapter 3

Beginning the Installation

The chapter contains the following sections:

- “Reviewing Safety Precautions” on page 66
- “Choosing a Site for the Switch” on page 70
- “Unpacking the Switch” on page 72
- “Installation Options” on page 75
- “Hardware Options” on page 78
- “Recording the Serial Number and MAC Address” on page 80
- “Installing the Switch on a Table” on page 81

Note

For installation instructions for the GS970EMX/10 Switch, refer to the *GS970EMX Series Installation Guide for Standalone Switches*.

Reviewing Safety Precautions

Review the following safety precautions before beginning the installation procedure.

Note

Safety statements that have the  symbol are translated into multiple languages in the *Translated Safety Statements* document at www.alliedtelesis.com/en/documents/translated-safety-statements.

Note

Les consignes de sécurité portant le symbole  sont traduites dans plusieurs langues dans le document *Translated Safety Statements*, disponible à l'adresse www.alliedtelesis.com/en/documents/translated-safety-statements.



Warning

Class 1 Laser product.  L1



Warning

Do not stare into the laser beam.  L2



Warning

Do not look directly at the fiber optic cable ends or inspect the cable ends with an optical lens.  L6



Warning

To prevent electric shock, do not remove the cover. No user-serviceable parts inside. This unit contains hazardous voltages and should only be opened by a trained and qualified technician. To avoid the possibility of electric shock, disconnect electric power to the product before connecting or disconnecting the LAN cables.
 E1



Warning

Do not work on equipment or cables during periods of lightning activity.  E2



Warning

Power cord is used as a disconnection device. To de-energize equipment, disconnect the power cord. ⚡ E3



Warning

Class I Equipment. This equipment must be earthed. The power plug must be connected to a properly wired earth ground socket outlet. An improperly wired socket outlet could place hazardous voltages on accessible metal parts. ⚡ E4

Note

Pluggable Equipment. The socket outlet shall be installed near the equipment and shall be easily accessible. ⚡ E5



Caution

Air vents must not be blocked and must have free access to the room ambient air for cooling. ⚡ E6



Warning

Operating Temperatures. This product is designed for a maximum ambient temperature of 45 degrees C. ⚡ E57

Note

All Countries: Install product in accordance with local and National Electrical Codes. ⚡ E8



Warning

Only trained and qualified personnel are allowed to install or replace this equipment. ⚡ E14



Caution

Circuit Overloading: Consideration should be given to the connection of the equipment to the supply circuit and the effect that overloading of circuits might have on overcurrent protection and supply wiring. Appropriate consideration of equipment nameplate ratings should be used when addressing this concern. ⚡ E21



Caution

Risk of explosion if battery is replaced by an incorrect type. Replace only with the same or equivalent type recommended by the manufacturer. Dispose of used batteries according to the manufacturer's instructions. *↻* E22



Warning

Mounting of the equipment in the rack should be such that a hazardous condition is not created due to uneven mechanical loading. *↻* E25

Note

Use dedicated power circuits or power conditioners to supply reliable electrical power to the device. *↻* E27



Caution

The chassis may be heavy and awkward to lift. Allied Telesis recommends that you get assistance when mounting the chassis in an equipment rack. *↻* E28

Note

If installed in a closed or multi-unit rack assembly, the operating ambient temperature of the rack environment may be greater than the room ambient temperature. Therefore, consideration should be given to installing the equipment in an environment compatible with the manufacturer's maximum rated ambient temperature (T_{mra}).
↻ E35



Caution

Installation of the equipment in a rack should be such that the amount of air flow required for safe operation of the equipment is not compromised. *↻* E36



Warning

Reliable earthing of rack-mounted equipment should be maintained. Particular attention should be given to supply connections other than direct connections to the branch circuits (e.g., use of power strips).
↻ E37



Caution

The unit does not contain serviceable components. Please return damaged units for servicing. *↻* E42



Warning

The temperature of an active SFP transceiver may exceed 40° C (158° F). Exercise caution when handling with unprotected hands. *↻* E43



Caution

You have to reset the switch to disable the VCStack feature. Some network traffic may be lost if the device is already connected to a live network. *↻* E75



Warning

Switches should not be stacked on top of one another on a table or desktop because that could present a personal safety hazard if you need to move or replace switches. *↻* E76



Warning

A transceiver can be damaged by static electricity. Be sure to observe all standard electrostatic discharge (ESD) precautions, such as wearing an anti-static wrist strap, to avoid damaging the device. *↻* E77

Choosing a Site for the Switch

Site and enclosure requirements are described in the following sections:

- “Site Requirements,” next
- “Enclosure Requirements” on page 71

Site Requirements

Observe these site requirements when planning the installation.

- The GS970EMX/20 and GS970EMX/28 Switches are fanless.
- The GS970EMX/52 Switch has a single fan inside the rear panel. Airflow direction is from front-to-back, with the fan pulling air out of the chassis.
- You should verify that the temperature range and ventilation at the installation site are suitable for the device, and that there is adequate air flow around the unit for cooling. The operating temperature range of the switches is provided in “Environmental Specifications” on page 166.
- If you plan to install the switch in an equipment rack, verify that the rack is safely secured so that it will not tip over. Devices in a rack should be installed starting at the bottom, with the heavier devices near the bottom of the rack.
- If you plan to install the switch on a table, verify that the table is level and stable.
- The power outlet should be located near the switch and be easily accessible.
- The site should allow for easy access to the ports on the front of the switch, so that you can easily connect and disconnect cables, and view the port LEDs.
- Do not install the switch in a wiring or utility box without adequate airflow. The switch might overheat and fail. Refer to “Enclosure Requirements” on page 71.
- The site should not expose the switch to moisture or water.
- The site should be a dust-free environment.
- The site should include dedicated power circuits or power conditioners to supply reliable electrical power to the network devices.
- The site should not expose the copper cabling to sources of electrical noise, such as radio transmitters, broadband amplifiers, power lines, electric motors, and fluorescent fixtures.
- Switch ports are suitable for intra-building connections, or where non-exposed cabling is required.
- Do not place objects on top of the switch.



Warning

Switches should not be stacked on top of one another on a table or desktop because that could present a personal safety hazard if you need to move or replace switches. *see* E76

Enclosure Requirements

Observe these guidelines when installing the switch in an enclosure:

- Verify that the enclosure has adequate airflow so that unit does not overheat.
- Select an enclosure that is large enough for the switch and all other included equipment.
- The enclosure size must be determined by considering multiple factors, including the outside ambient temperature, total heat generated by the installed equipment, sealed or unsealed enclosure type, enclosure material, paint color, mounting method (wall, pole, ground, etc.), and sun exposure. The smaller enclosure size you choose, the higher the risk of overheating the product faces.

Note

If the product overheats in an enclosure that was selected without taking into account these factors, the warranty of the product might be voided. Consult Allied Telesis when assistance is needed.

- The enclosure's BTU/hour rating must be higher than the total BTU/hour values of installed equipment, over the expected operating temperature range. For the operating temperature ratings, refer to Table 19, "Storage and Operating Environment Specifications" on page 166.
- Be sure to review the enclosure's installation guide for rules and restrictions on site requirements, and to follow all guidelines and safety warnings.

Unpacking the Switch

The GS970EMX/20 Switch comes with the accessory items in Figure 25.

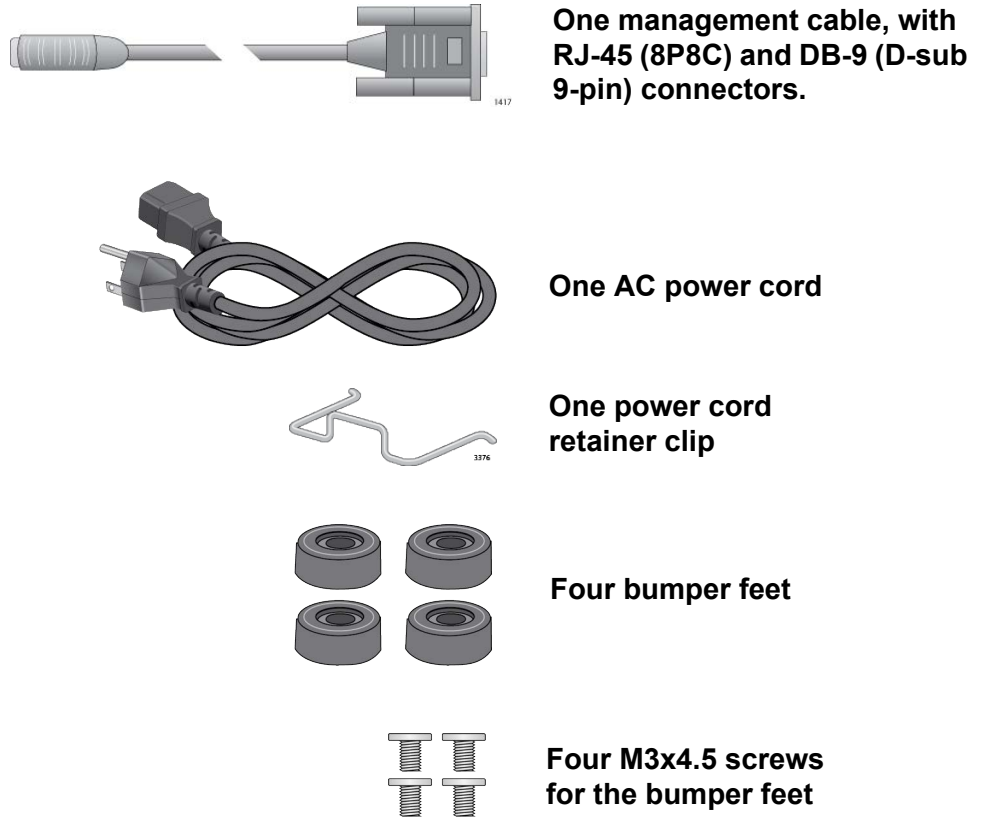

Figure 25. Accessory Items Included with the GS970EMX/20 Switch

Note

Please retain the original packaging material in the event you need to return the unit to Allied Telesis.

The GS970EMX/28 Switch comes with the accessory items in Figure 26.



One management cable, with RJ-45 (8P8C) and DB-9 (D-sub 9-pin) connectors.

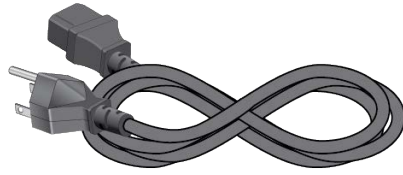

One AC power cord



One power cord retainer clip

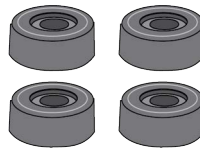

Four bumper feet

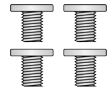

Four M3x4.5 screws for the bumper feet

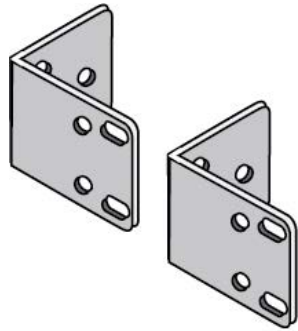

Two equipment rack brackets



Six 4x8mm screws for attaching the brackets to the switch.

Figure 26. Accessory Items Included with the GS970EMX/28 Switch

The GS970EMX/52 Switch comes with the accessory items in Figure 27.

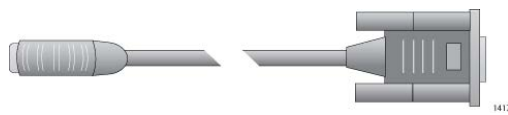

One management cable, with RJ-45 (8P8C) and DB-9 (D-sub 9-pin) connectors

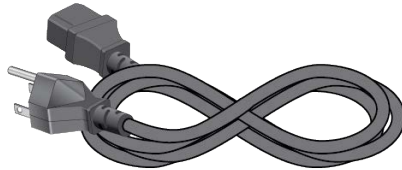

One AC power cord



One power cord retainer clip

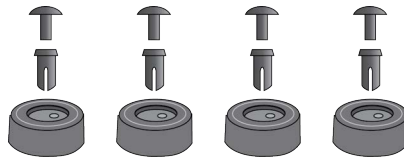

Four bumper feet with rivets

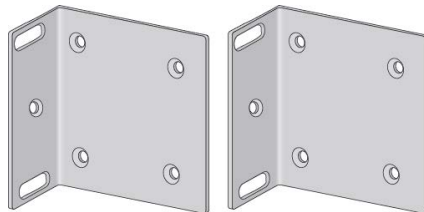

Two wall/equipment rack brackets



Eight 3x6mm Phillips-head screws for attaching the brackets to the switch

Figure 27. Accessory Items Included with the GS970EMX/52 Switch

Note

If any item is missing or damaged, contact your Allied Telesis sales representative for assistance.

Installation Options

The following sections illustrate the installation options for the switches.

GS970EMX/20 Switch

Figure 28 illustrates the installation options for the GS970EMX/20 Switch.

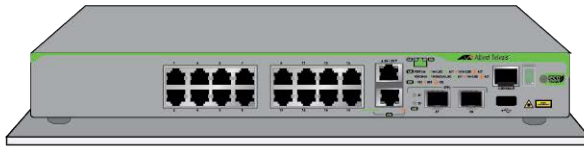
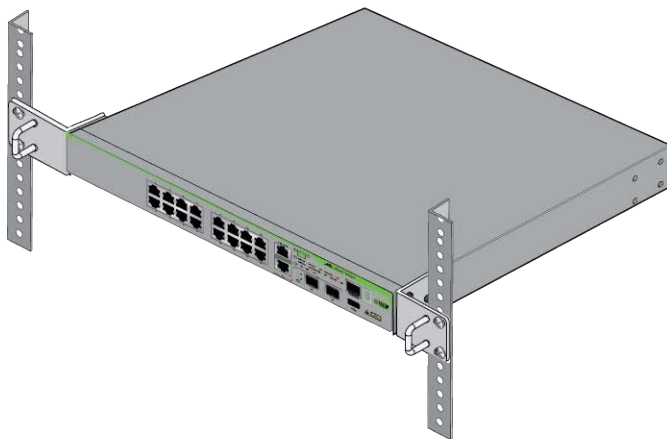
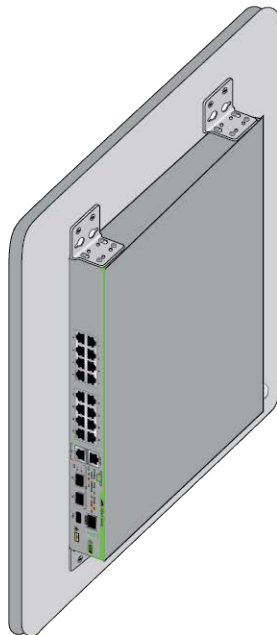

Table or desktop with the bumper feet included with the switch.



Standard 19-inch equipment rack with the RKMT-J13 equipment rack brackets kit. Kit sold separately.



Wall installation with the BRKT-J24 wall brackets kit. Kit sold separately.

Figure 28. Installation Options for the GS970EMX/20 Switch

GS970EMX/28 Switch

Figure 28 illustrates the installation options for the GS970EMX/28 Switch.

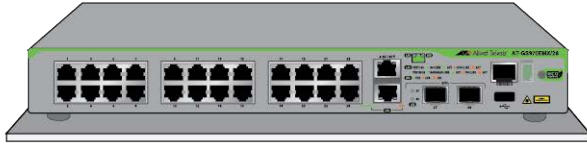
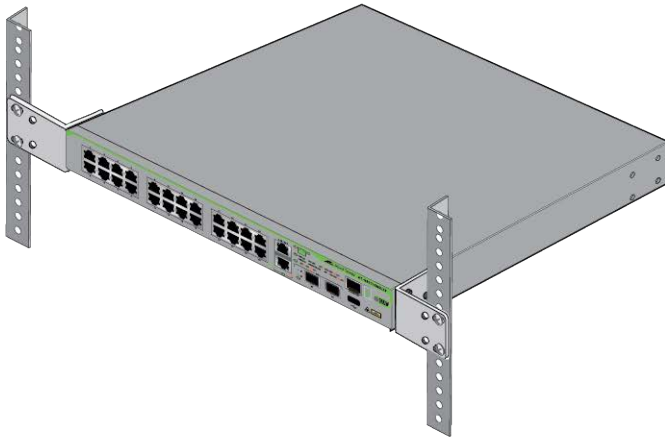
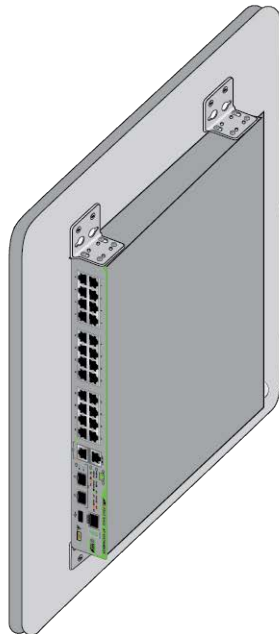

Table or desktop with the bumper feet included with the switch.



Standard 19-inch equipment rack with the equipment rack brackets included with the switch, or the RKMT-J13 equipment rack brackets kit. Kit sold separately.



Wall installation with the BRKT-J24 wall brackets kit. Kit sold separately.

Figure 29. Installation Options for the GS970EMX/28 Switch

GS970EMX/52 Switch

Figure 30 illustrates the installation options for the GS970EMX/52 Switch.

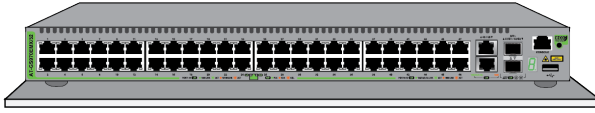
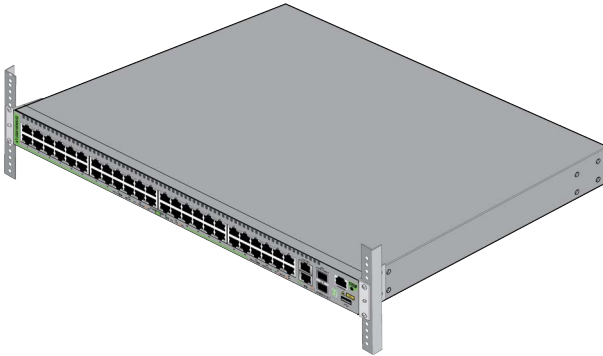
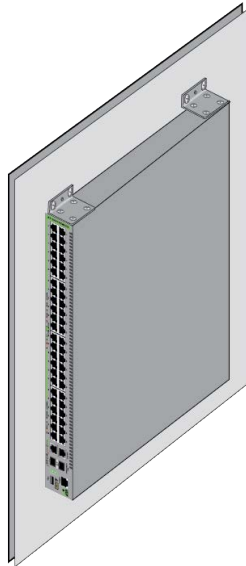

Table or desktop with the bumper feet included with the switch.



Standard 19-inch equipment rack with the wall/equipment rack brackets included with the switch.



Wall installation with the wall/equipment rack brackets included with the switch.

Figure 30. Installation Options for the GS970EMX/52 Switch

Hardware Options

The following hardware options for the GS970EMX/20 and GS970EMX/28 Switches are sold separately.

Note

The GS970EMX/52 Switch does not require the hardware options.

RKMT-J13 Equipment Rack Brackets Kit

Installing the GS970EMX/20 Switch in a standard 19-inch equipment rack requires the RKMT-J13 brackets kit. Refer to Figure 31. You can install the switch with the front panel flush with or recessed 50mm (2 in.) behind the front of the equipment rack. For instructions, refer to Chapter 4, “Installing the GS970EMX/20 Switch in an Equipment Rack” on page 85.

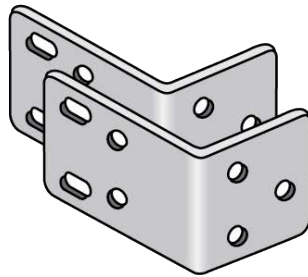

Two equipment rack brackets

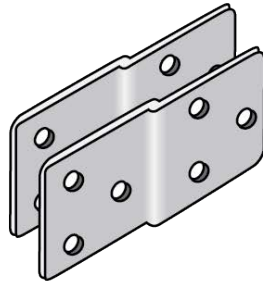

Two bracket extenders

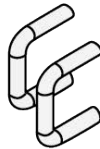

Two handles



Four 3x6mm screws for attaching the handles to the brackets



Twelve 4x8mm screws for attaching the brackets to the switch

Figure 31. RKMT-J13 Equipment Rack Brackets Kit for the GS970EMX/20 Switch

Note

The GS970EMX/28 and GS970EMX/52 Switches come with brackets for equipment rack installations.

BRKT-J24 Wall Brackets Kit

Installing the GS970EMX/20 and GS970EMX/28 Switches on a wall requires the BRKT-J24 wall brackets kit. Refer to Figure 32. For instructions, refer to Chapter 7, “Installing GS970EMX/20, GS970EMX/28, and GS970EMX/52 Switches on a Wall” on page 99.

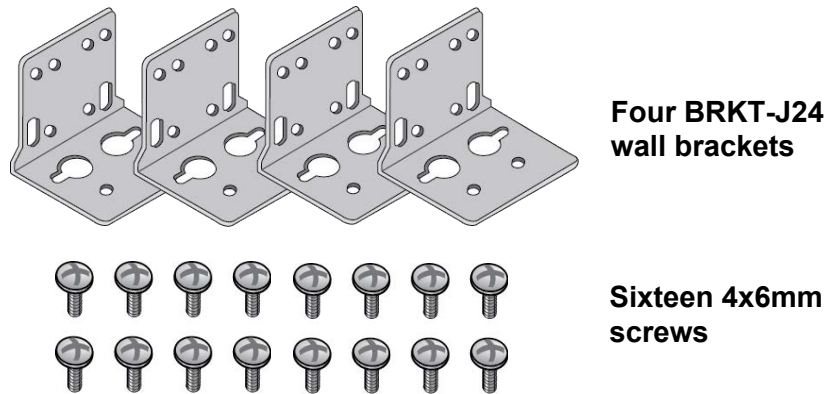

Figure 32. BRKT-J24 Wall Brackets Kit for the GS970EMX/20 and GS970EMX/28 Switches

Note

The GS970EMX/52 Switch comes with brackets for installing the device on a wall.

Recording the Serial Number and MAC Address

The serial number and MAC address of the switch are located on labels on the bottom panel. Refer to Figure 33. If you need to record the numbers for your records, you should do so before installing the device.

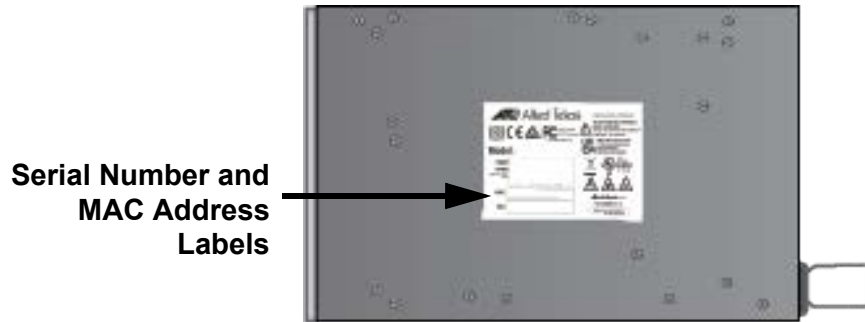

Figure 33. Serial Number and MAC Address Labels

Note

You can also view the serial number and MAC address of the switch with the `SHOW SYSTEM SERIALNUMBER` and `SHOW SYSTEM MAC` commands in the User Exec and Privileged EXEC modes of the AlliedWare Plus management software.

Installing the Switch on a Table

You can operate the switch on a table or desktop. Refer to Figure 34.



Figure 34. Switch Installation on a Table

The following guidelines are in addition to those in “Choosing a Site for the Switch” on page 70:

- Do not stack switches on a table.
- Do not install the switch upside down on a table.
- Do not install the switch vertically on a table.

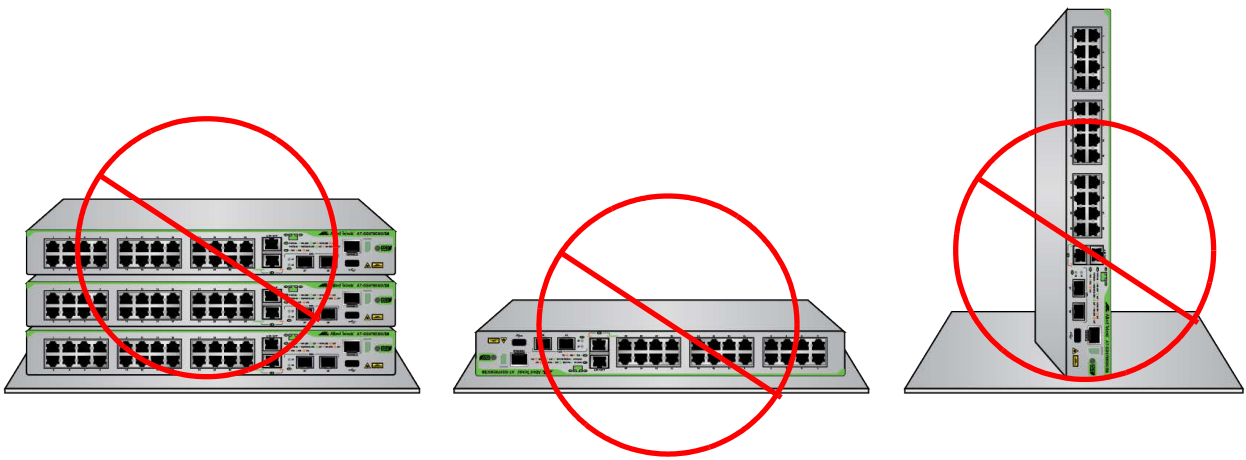

Figure 35. Unsupported Table Installations



Warning

Switches should not be stacked on a table or desktop. They could present a physical safety hazard should you move or replace switches. *GS* E91



Warning

The device is heavy. Use both hands to lift it. You might injure yourself or damage the device if you drop it. *GS* E94

Note

Bumper feet are required for tabletop installation. They promote cooling by allowing airflow beneath the switch.

To install the switch on a table, perform the following procedure:

1. Verify that the selected site is suitable for the unit by reviewing “Reviewing Safety Precautions” on page 66 and “Choosing a Site for the Switch” on page 70.
2. Verify that the table is strong enough to support the weight of the switch.
3. Verify that the accessory kit came with all the appropriate items. Refer to “Unpacking the Switch” on page 72.
4. Lift the switch from the shipping box and place it upside down on the table.
5. For the GS970EMX/20 and GS970EMX/28 Switches, attach the four bumper feet to the bottom corners of the switch using the four 3x4.5mm screws and a Phillips-head screwdriver. Refer to Figure 36.

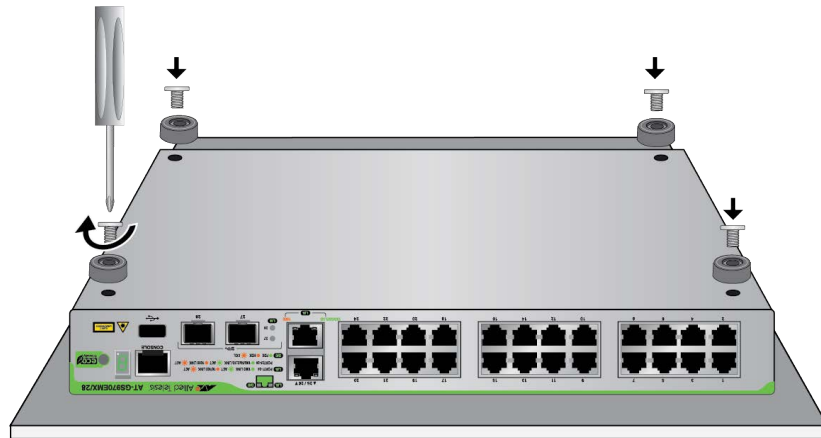

Figure 36. Attaching the Bumper Feet

6. For the GS970EMX/52 Switch, do the following:
 - a. Place a bumper foot over one of the corner holes on the bottom panel of the switch. Refer to Figure 37 on page 83.
 - b. Insert a rivet to secure the bumper foot.
 - c. Repeat this step to install the remaining bumper feet.

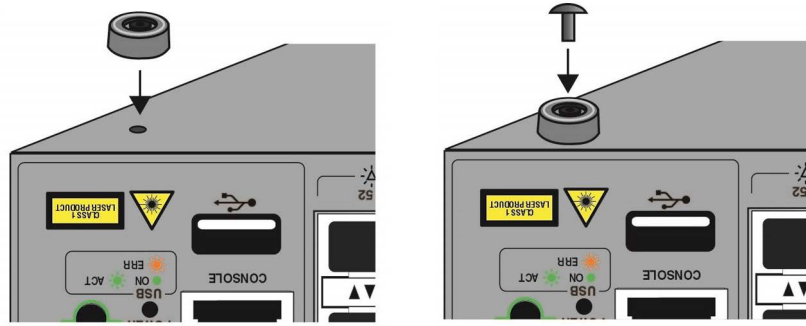

Figure 37. Attaching Bumper Feet on the GS970EMX/52 Switch

7. Turn the switch over, placing it on the bumper feet.
8. Go to Chapter 8, “Displaying the Hardware Status and AlliedWare Plus Version Number” on page 109.

Chapter 4

Installing the GS970EMX/20 Switch in an Equipment Rack

This chapter contains the installation instructions for the GS970EMX/20 Switch in a standard 19-inch equipment rack with the RKMT-J13 equipment rack brackets kit. Here are the sections in the chapter:

- ❑ “Introduction” on page 86
- ❑ “Installing the GS970EMX/20 Switch” on page 87

Introduction

Installing the GS970EMX/20 Switch in a standard 19-inch equipment rack requires the RKMT-J13 equipment rack brackets kit. The kit allows you to install the switch with its front panel flush with or recessed 50mm (2 in.) behind the front of the equipment rack. Refer to Figure 38. The kit is sold separately.

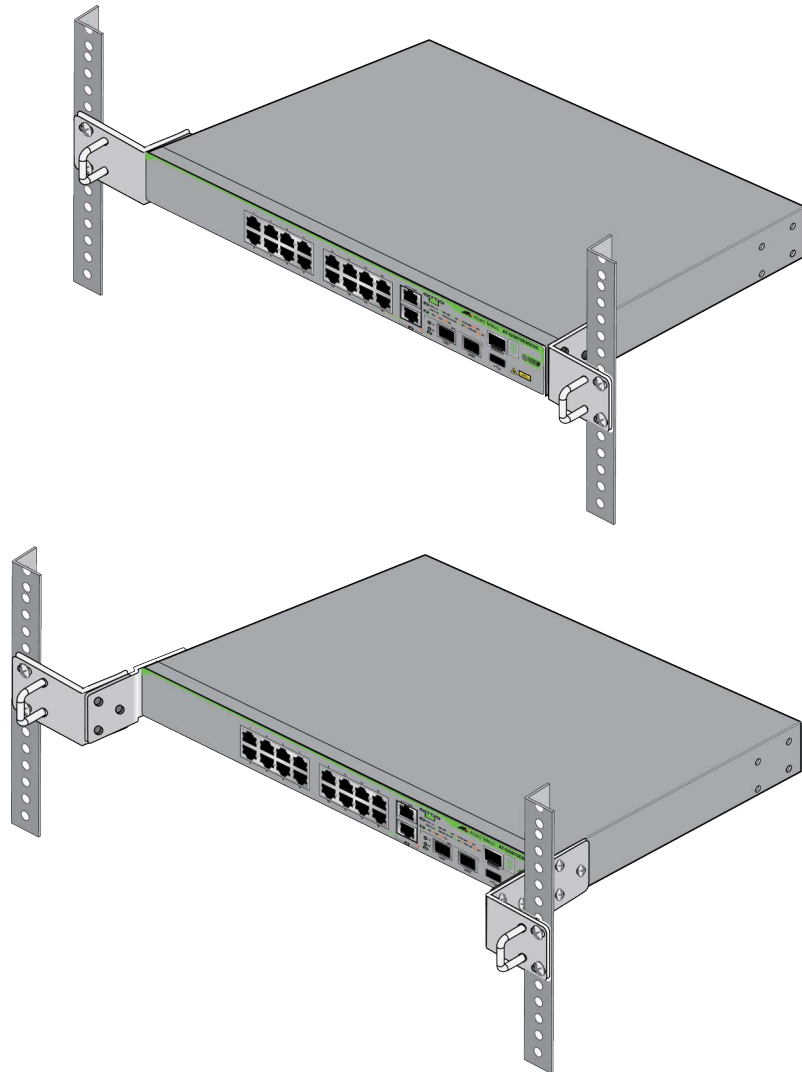

Figure 38. GS970EMX/20 Switch with RKMT-J13 Equipment Rack Brackets Kit

Note

You can install the GS970EMX/28 Switch in an equipment rack using the two equipment rack brackets that come with it or the RKMT-J13 kit.

Installing the GS970EMX/20 Switch

This section contains the procedure for installing the GS970EMX/20 Switch in standard 19-inch equipment rack with the RKMT-J13 equipment rack brackets kit. Here are the required items:

- ❑ One RKMT-J13 equipment rack brackets kit.
- ❑ Cross-head screwdriver (not provided).
- ❑ Flat-head screwdriver (not provided).
- ❑ Four standard equipment rack screws (not provided).

To install the GS970EMX/20 Switch in a 19-inch equipment rack, perform the following procedure:

1. Place the switch on a table.
2. Verify the contents of the RKMT-J13 equipment rack brackets kit. Refer to Figure 31 on page 78 for the kit contents.
3. Attach the handles to the RKMT-J13 brackets with the four 3x6mm screws included in the kit. Attaching the handles is optional. Refer to Figure 39.

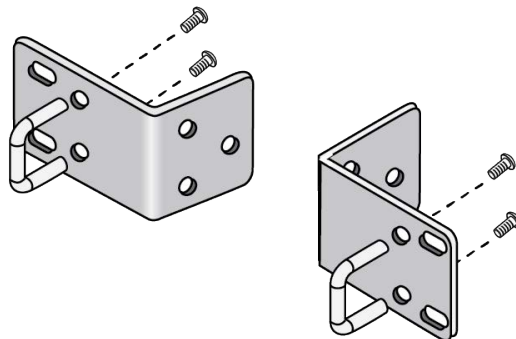

Figure 39. Attaching the Handles to the RKMT-J13 Brackets

4. If you want to recess the front of the switch in the equipment rack 50mm (2 in.), attach the extenders to the brackets with six of the 4x8mm screws included in the kit. Refer to Figure 40 on page 88.

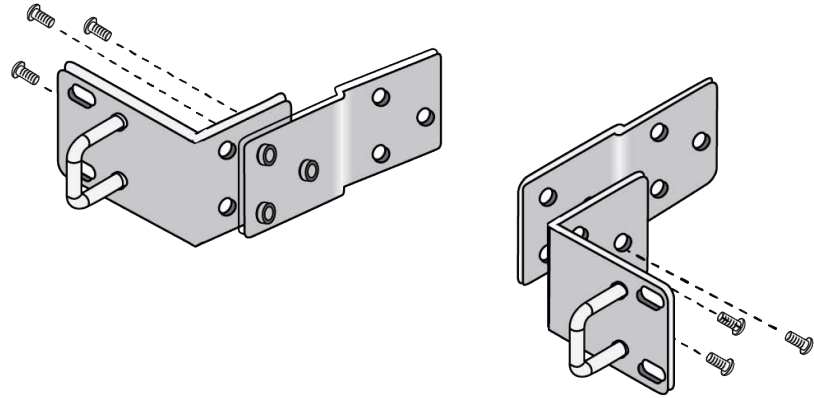

Figure 40. Attaching the Extenders to the RKMT-J13 Brackets

5. Attach the brackets to the sides of the switch with six of the 4x8mm screws included in the kit. Refer to Figure 41.

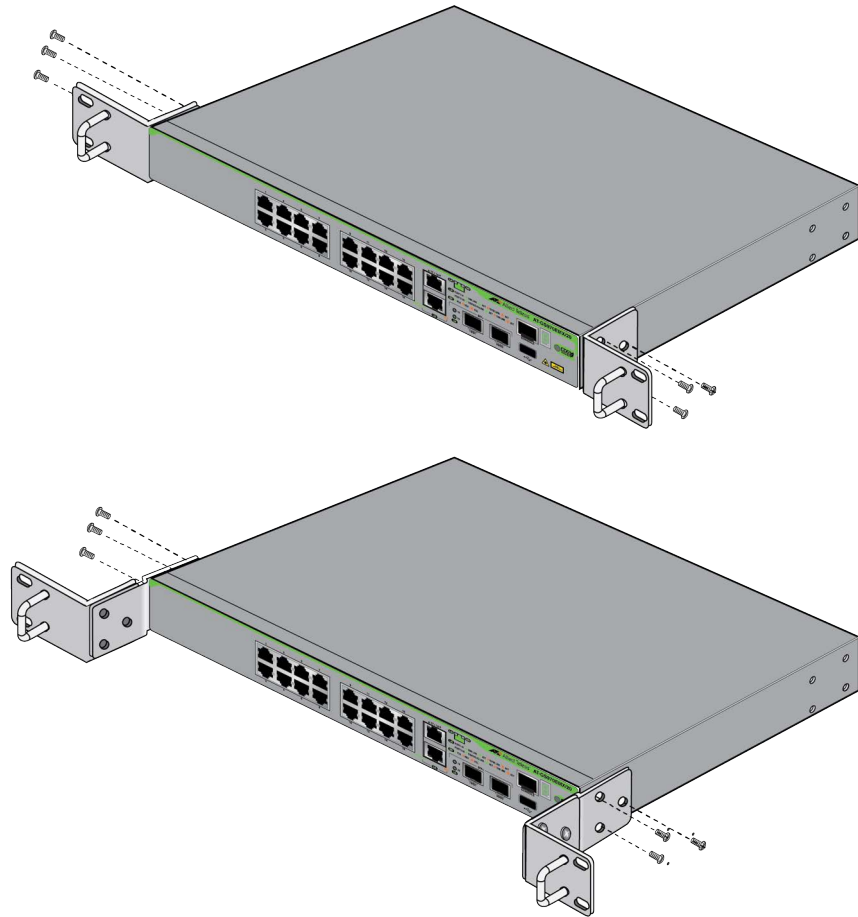

Figure 41. Attaching the RKMT-J13 Brackets to the GS970EMX/20 Switch

6. Have another person hold the switch at the selected location in the equipment rack while you secure it using four standard equipment rack screws (not provided). Refer to Figure 42.

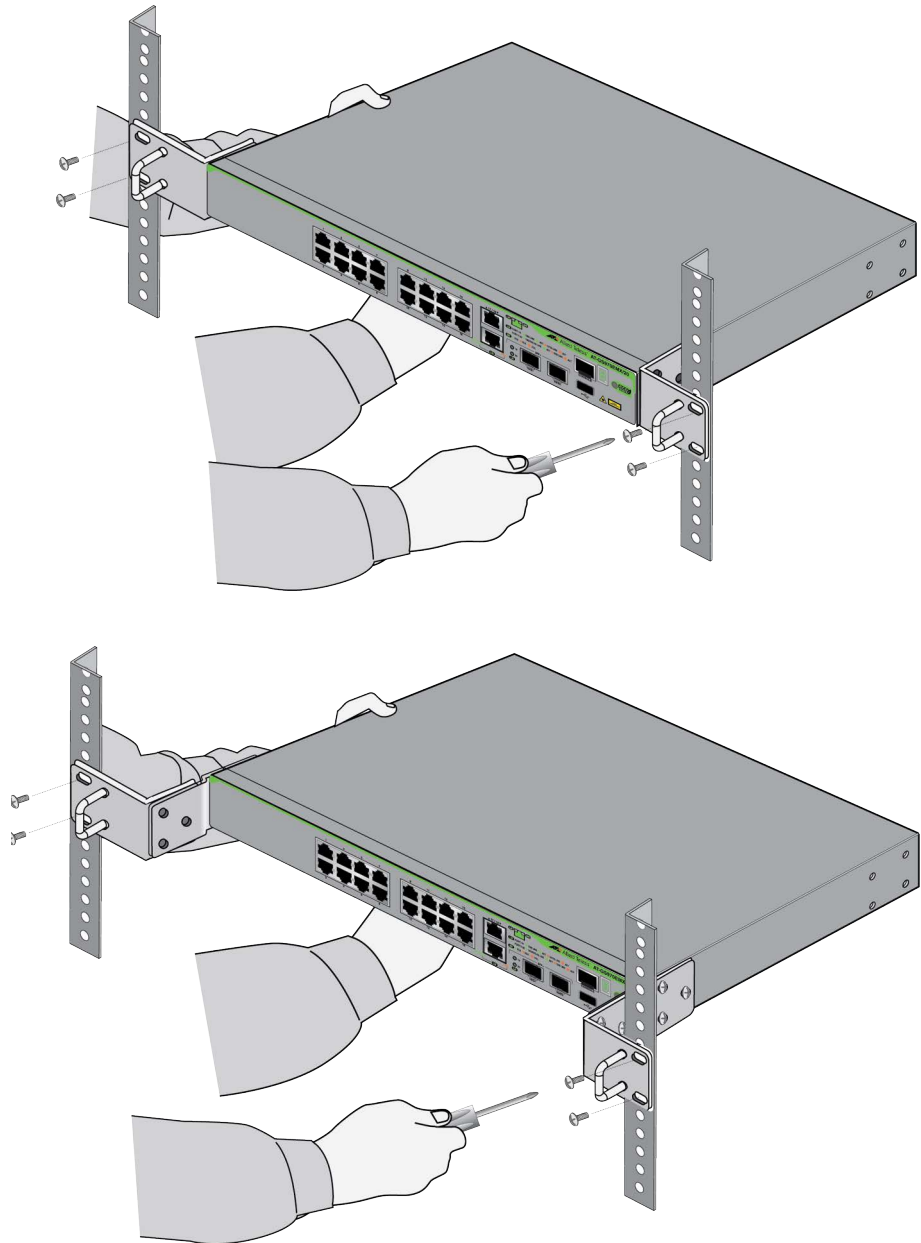

Figure 42. Securing the GS970EMX/20 Switch in a Standard 19-inch Equipment Rack

7. Go to Chapter 8, “Displaying the Hardware Status and AlliedWare Plus Version Number” on page 109.

Chapter 5

Installing the GS970EMX/28 Switch in an Equipment Rack

This chapter contains the installation instructions for the GS970EMX/28 Switch in a standard 19-inch equipment rack. Here are the sections:

- “Introduction” on page 92
- “Installing the GS970EMX/28 Switch” on page 93

Introduction

The GS970EMX/28 Switch comes with two brackets for installing the device in a standard 19-inch equipment rack. Refer to Figure 43. The brackets and screws are shown in Figure 26 on page 73.

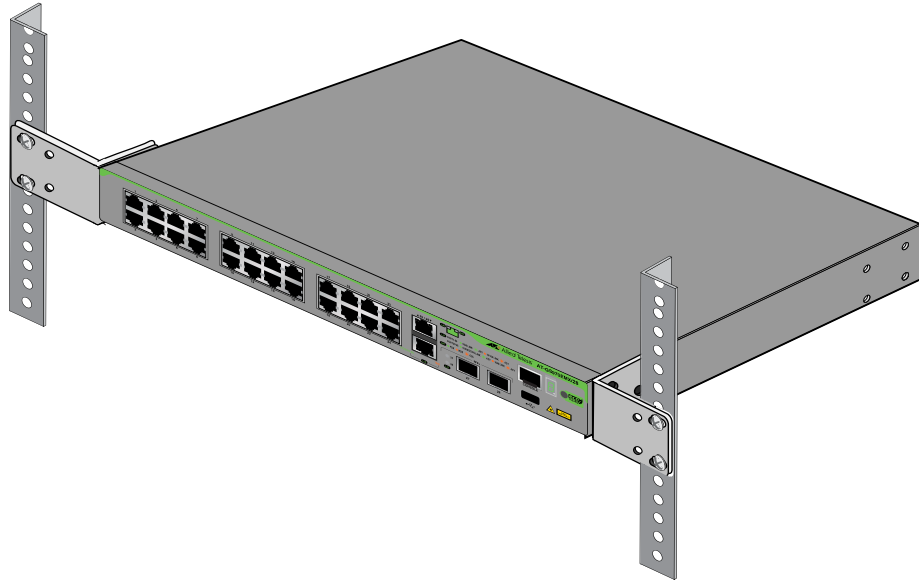

Figure 43. GS970EMX/28 Switch Installed in a Standard 19-inch Equipment Rack

Note

You can install the GS970EMX/28 Switch in an equipment rack using the brackets that come with it or the RKMT-J13 equipment rack brackets kit, which is sold separately. The kit lets you install the switch with the front panel recessed 50mm (2 in.) from the front of the equipment rack. Refer to “RKMT-J13 Equipment Rack Brackets Kit” on page 78.

Installing the GS970EMX/28 Switch

This section contains the procedure for installing the GS970EMX/28 Switch in a standard 19-inch equipment rack with the two equipment rack brackets included with the device. Here are the required items:

- ❑ Two equipment rack brackets (included with the switch).
- ❑ Six M4x8mm bracket screws (included with the switch).
- ❑ Cross-head screwdriver (not provided).
- ❑ Four standard equipment rack screws (not provided).

To install the GS970EMX/28 Switch in a 19-inch equipment rack, perform the following procedure:

1. Place the switch on a table.
2. Attach the equipment rack brackets to the sides of the switch with the six 4x8mm screws included with the device. Refer to Figure 44.

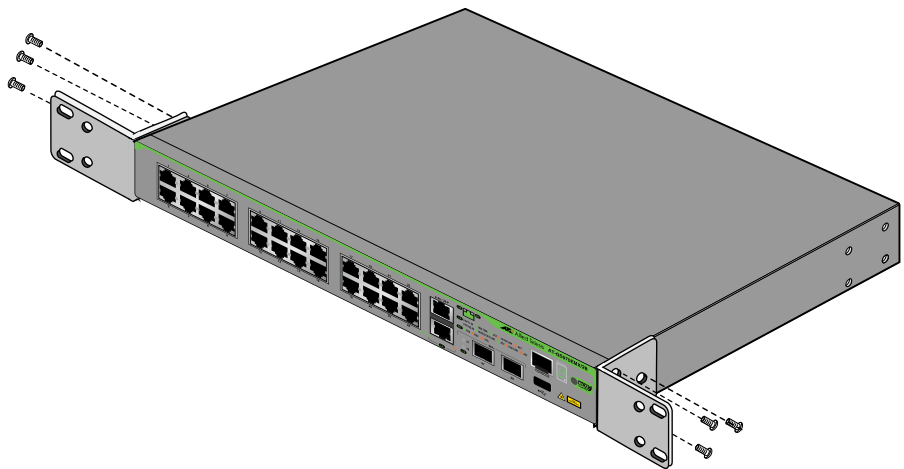

Figure 44. Attaching the Equipment Rack Brackets to the GS970EMX/28 Switch

3. Have another person hold the switch at the selected location in the equipment rack while you secure it using four standard equipment rack screws (not provided). Refer to Figure 45 on page 94.
4. Go to Chapter 8, “Displaying the Hardware Status and AlliedWare Plus Version Number” on page 109.

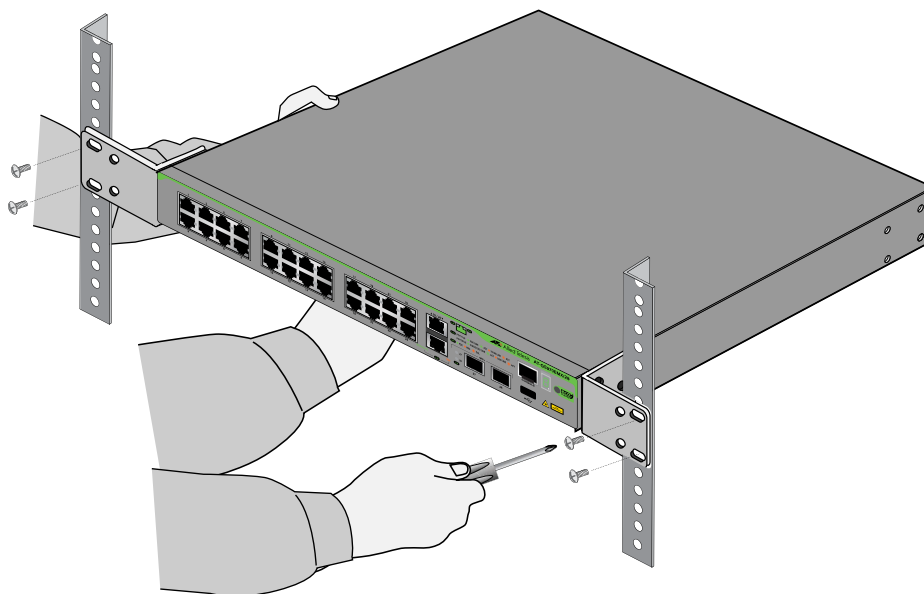

Figure 45. Securing the GS970EMX/28 Switch in a Standard 19-inch Equipment Rack

Chapter 6

Installing the GS970EMX/52 Switch in an Equipment Rack

This chapter contains the installation instructions for the GS970EMX/52 Switch in a standard 19-inch equipment rack. Here are the sections:

- “Introduction” on page 96
- “Installing the GS970EMX/52 Switch” on page 97

Introduction

The GS970EMX/52 Switch comes with two brackets and eight screws for installing the device in a standard 19-inch equipment rack. Refer to Figure 27 on page 74.

The switch has two sets of four screw holes on the left and right sides for the brackets. Refer to Figure 46.

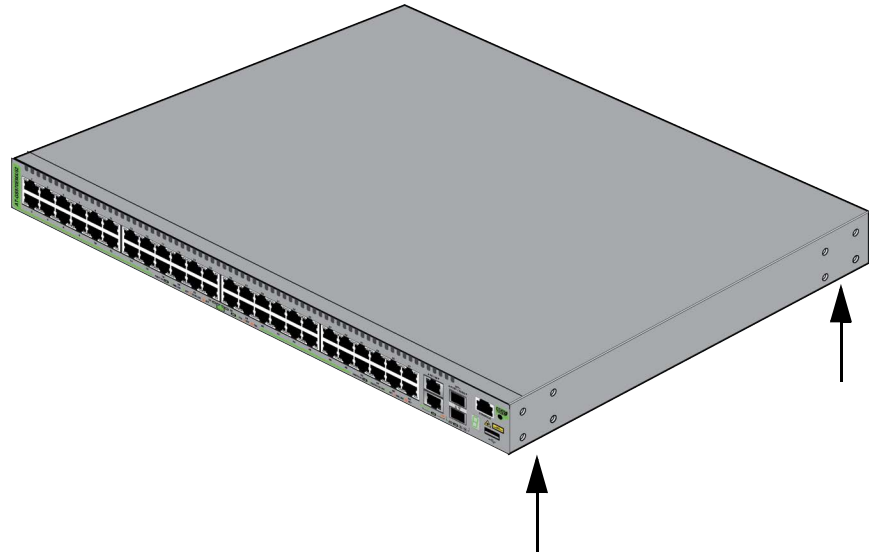

Figure 46. Bracket Screw Holes on the GS970EMX/52 Switch

You can install the brackets so that the front of the switch is flush with or extending in front of the equipment rack. Refer to Figure 47.

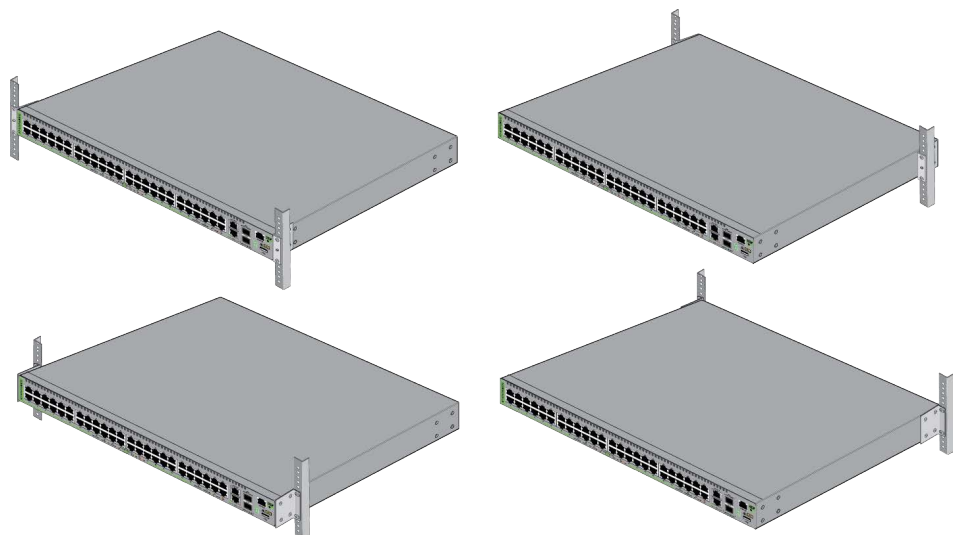

Figure 47. Equipment Rack Bracket Positions for the GS970EMX/52 Switch

Installing the GS970EMX/52 Switch

This section contains the procedure for installing the GS970EMX/52 Switch in a standard 19-inch equipment rack. Here are the required items:

- ❑ Two wall/equipment rack brackets (included with the switch).
- ❑ Eight M4x8mm bracket screws (included with the switch).
- ❑ Cross-head screwdriver (not provided).
- ❑ Four standard equipment rack screws (not provided).



Warning

The device is heavy. Ask for assistance before moving or lifting it to avoid injuring yourself or damaging the equipment. ⚡ E94

To install the switch in a 19-inch equipment rack, perform the following procedure:

1. Place the switch on a table.

Note

If the bumper feet are attached to the bottom of the switch, remove them with a flathead screwdriver before continuing.

2. Attach the wall/equipment rack brackets to the sides of the switch in the selected position, with the eight M4x8mm screws included with the switch. Figure 48 shows the brackets installed so that the front of the switch is flush with the front of the equipment rack.

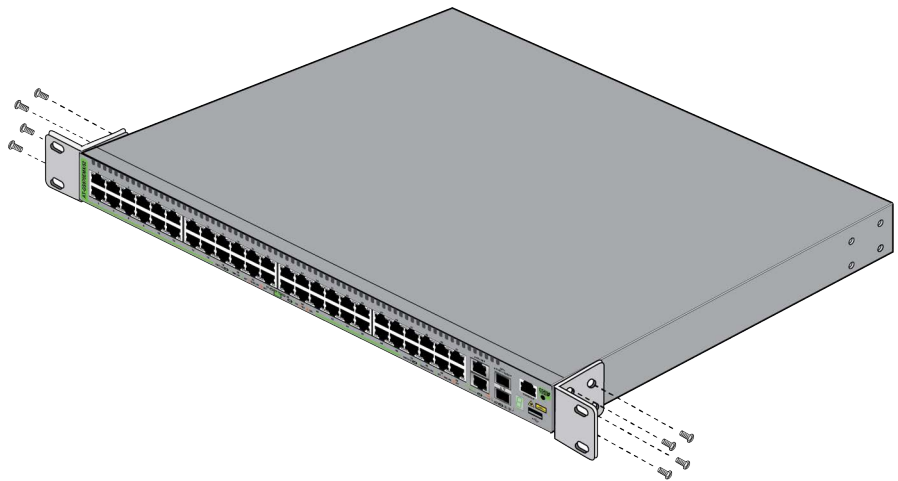

Figure 48. Attaching the Equipment Rack Brackets to the GS970EMX/52 Switch

3. Have another person hold the switch at the selected location in the equipment rack while you secure it using four standard equipment rack screws (not provided). Refer to Figure 49.

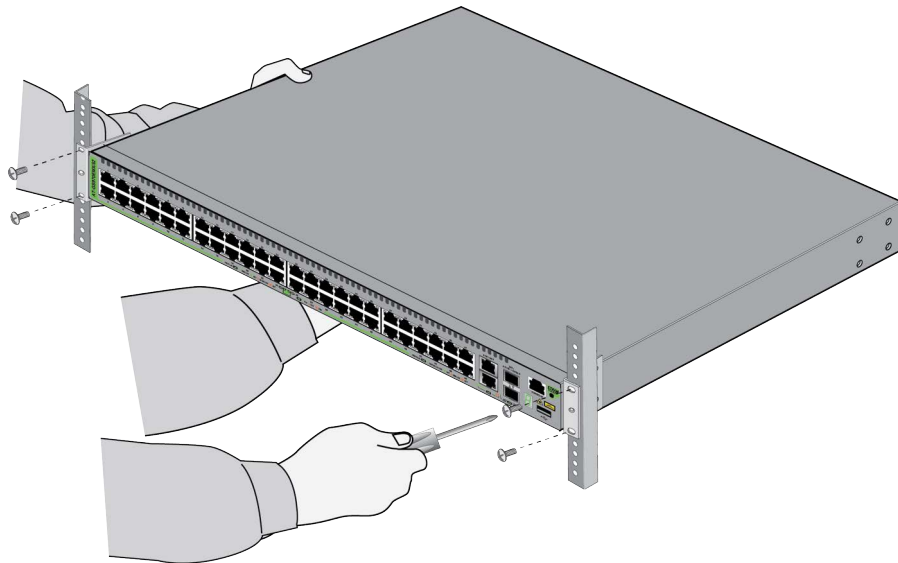

Figure 49. Securing the GS970EMX/52 Switch in a Standard 19-inch Equipment Rack

4. Go to Chapter 8, “Displaying the Hardware Status and AlliedWare Plus Version Number” on page 109.

Chapter 7

Installing GS970EMX/20, GS970EMX/28, and GS970EMX/52 Switches on a Wall

This chapter contains instructions for installing GS970EMX/20, GS970EMX/28, and GS970EMX/52 Switches on a wood or concrete wall. The chapter contains the following sections:

- ❑ “Installation Guidelines” on page 100
- ❑ “Plywood Base for a Wall with Wooden Studs” on page 103
- ❑ “Installing the Switch” on page 105

Installation Guidelines

The guidelines to installing GS970EMX/20, GS970EMX/28, and GS970EMX/52 Switches on a wall are listed here:

- ❑ The GS970EMX/20 and GS970EMX/28 Switches require the BRKT-J24 wall brackets kit for wall installations. The kit comes with four identical brackets. Refer to Figure 32 on page 79. The kit is sold separately.
- ❑ The GS970EMX/52 Switch is installed on a wall with the two wall/equipment rack brackets included with the unit. Refer to Figure 14 on page 50.
- ❑ You can install the switches with the front panels facing up, left or right. Refer to Figure 50.

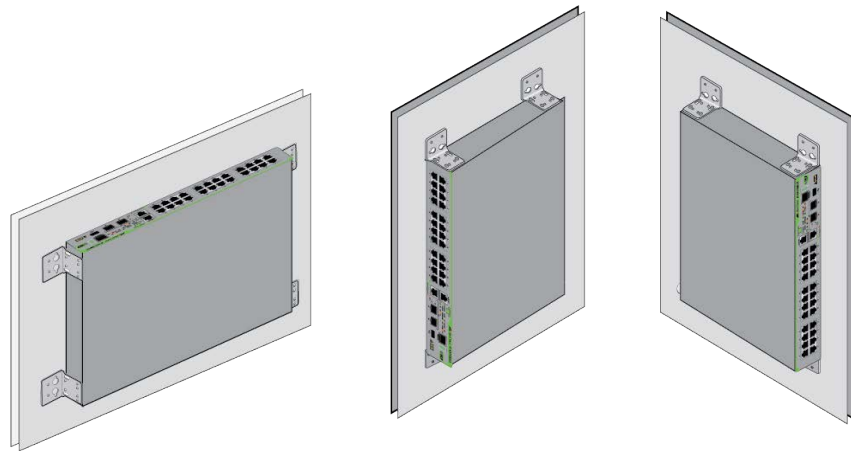

Figure 50. GS970EMX/20 and GS970EMX/28 Switches on a Wall with the BRKT-J24 Brackets Kit

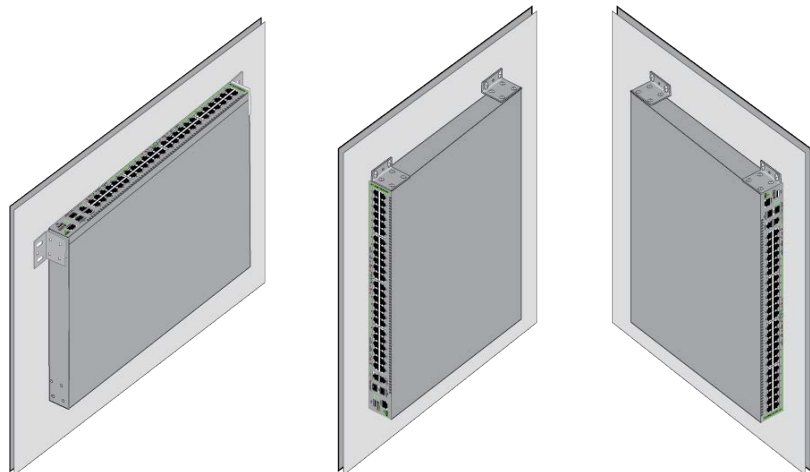

Figure 51. GS970EMX/52 Switch on a Wall

- ❑ Do not install switches with the front panels facing down. Refer to Figure 52.

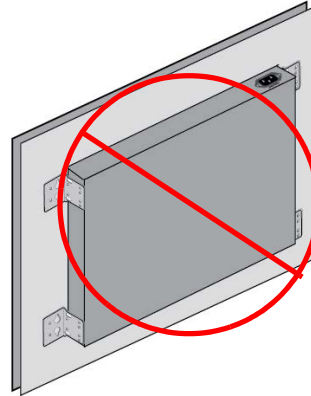

Figure 52. Unsupported Wall Installation of the GS970EMX/20, GS970EMX/28, and GS970EMX/52 Switches

Here are the guidelines to installing switches on a wall:

- ❑ You may install the switches on wooden or concrete walls.
- ❑ If you are installing the switches on a wall with wooden studs, you should install them on a plywood base. For more information, refer to “Plywood Base for a Wall with Wooden Studs” on page 103.
- ❑ You should not install the switches on a wall that has metal studs. Metal studs may not be strong enough to safely support the device.
- ❑ You should not install the switches on sheetrock or similar material. Sheetrock might not be strong enough to safely support the device.
- ❑ Attach the base to two wall studs with a minimum of four screws.
- ❑ The selected wall location should provide sufficient space from other devices or walls so that you can access the front and back panels, and for adequate air flow for ventilation.
- ❑ For wooden walls, use a stud finder to identify the middle of studs and hot electrical wiring.



Warning

The device is heavy. Ask for assistance before moving or lifting it to avoid injuring yourself or damaging the equipment. ⚡ E94



Warning

The device should be installed on a wall by a qualified building contractor. Serious injury to yourself or others or damage to the equipment may result if it is improperly fastened to the wall. ⚡ E105

Here are the required tools and material for installing the switch on a wall:

- ❑ For GS970EMX/20 and GS970EMX/28 Switches, one BRKT-J24 wall brackets kit for each switch. The kit is sold separately.
- ❑ For the GS970EMX/52 Switch, two wall/equipment rack brackets are included with the device.
- ❑ Four wall anchors and screws (not provided) The diameter of the screw holes in the brackets is 5mm.
- ❑ Cross-head screwdriver (not provided).
- ❑ Stud finder for a wooden wall, capable of identifying the middle of wall studs and hot electrical wiring (not provided).
- ❑ Drill and 1/4-inch carbide drill bit for a concrete wall (not provided).
- ❑ Plywood base if you are installing the switch on a wall with wooden studs (not provided), Refer to “Plywood Base for a Wall with Wooden Studs” on page 103 for illustrations.
- ❑ Four screws to attach the plywood base to the wall (not provided).

Plywood Base for a Wall with Wooden Studs

When installing the switch on a wall that has wooden studs, Allied Telesis recommends installing the device on a plywood base. (A plywood base is not required for concrete walls.) Refer to Figure 53.

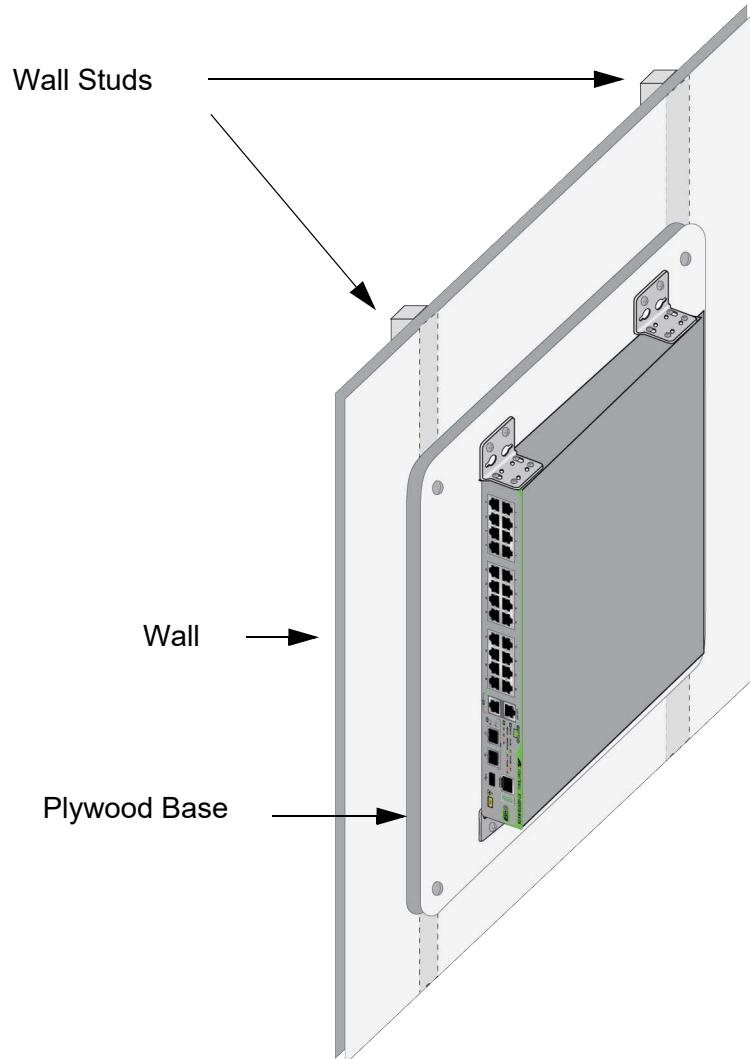

Figure 53. GS970EMX Switch on a Wall with a Plywood Base

The plywood base should be mounted on two studs in the wall. The recommended minimum dimensions of a plywood base for GS970EMX/20 and GS970EMX/28 Switches are listed here:

- ❑ Width: 55.9 centimeters (22 inches)
- ❑ Height: 50 centimeters (20 inches)
- ❑ Thickness: 2.5 centimeters (1 inch)

Recommended minimum dimensions of a plywood base for the GS970EMX/52 Switch are listed here:

- ❑ Width: 55.9 centimeters (22 inches)
- ❑ Height: 50 centimeters (22 inches)
- ❑ Thickness: 2.5 centimeters (1 inch)

The dimensions assume the wall studs are 41 centimeters (16 inches) apart. You might need to adjust the width of the base if the distance between the studs in your wall is different than the industry standard.

You should install the plywood base on the wall and then install the switch on the base. Refer to Figure 54.

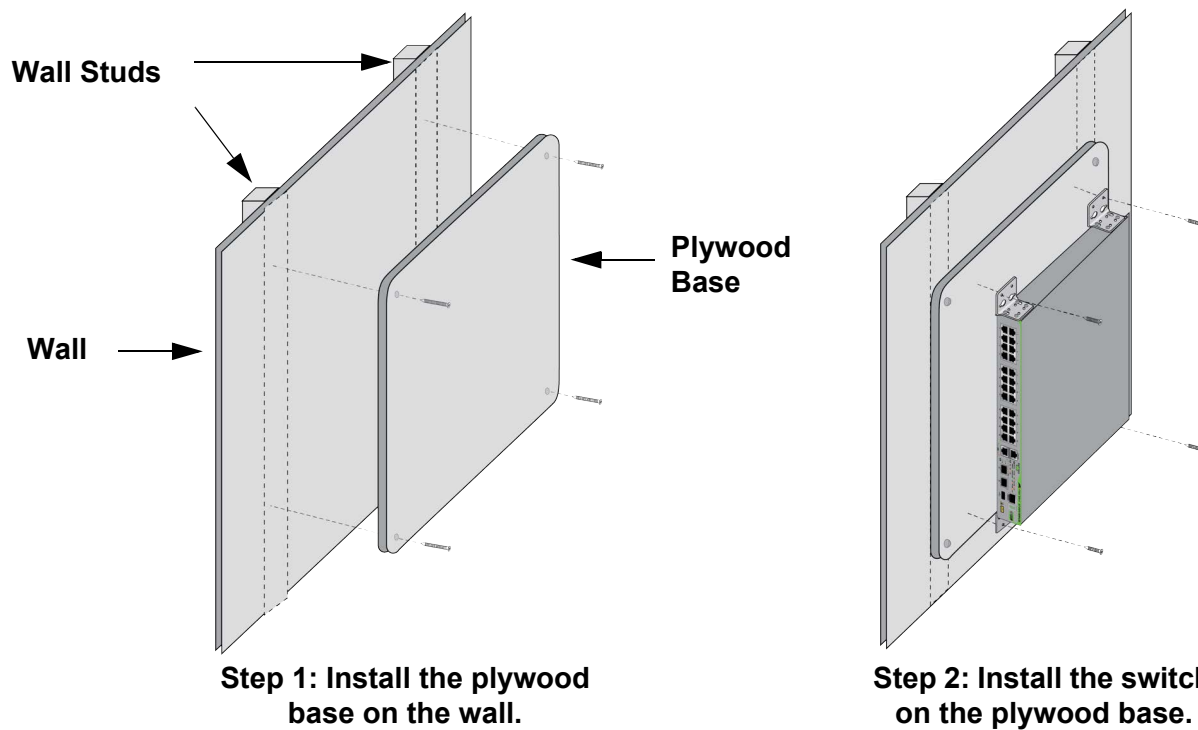

Figure 54. Steps to Installing GS970EMX Switches on a Plywood Base

Installing the Switch

This section contains the procedure for installing the switch on a wall. Review the following before performing the procedure:

- ❑ If you are installing the switch on a wall with wooden studs, the procedure assumes the plywood base is already mounted on the wall.
- ❑ Review “Reviewing Safety Precautions” on page 66 and “Choosing a Site for the Switch” on page 70 before performing this procedure.
- ❑ Allied Telesis recommends a minimum of two people for this procedure.



Warning

The device is heavy. Always ask for assistance before moving or lifting it to avoid injuring yourself or damaging the equipment.

 E94



Warning

The device should be installed on the wall by a qualified building contractor. Serious injury to yourself or others or damage to the equipment may result if it is improperly fastened to the wall.  E105

To install the switch, perform the following procedure:

1. Place the switch on a table.

Note

If the bumper feet are attached to the bottom on the switch, remove them before continuing.

2. For the GS970EMX/20 and GS970EMX/28 Switches, attach the four BRKT-J24 wall brackets to the sides of the switch, with the sixteen M4x6mm screws included in the kit. Refer to Figure 55.

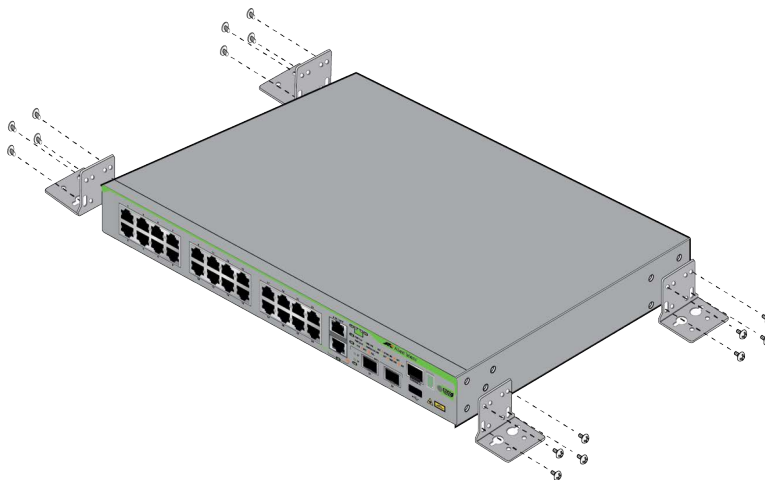

Figure 55. Attaching the BRKT-J24 Wall Brackets to the GS970EMX/20 and GS970EMX/28 Switches

3. For the GS970EMX/52 Switch, attach the two wall/equipment rack brackets to one side of the switch. Refer to Figure 56 and Figure 57 on page 107.

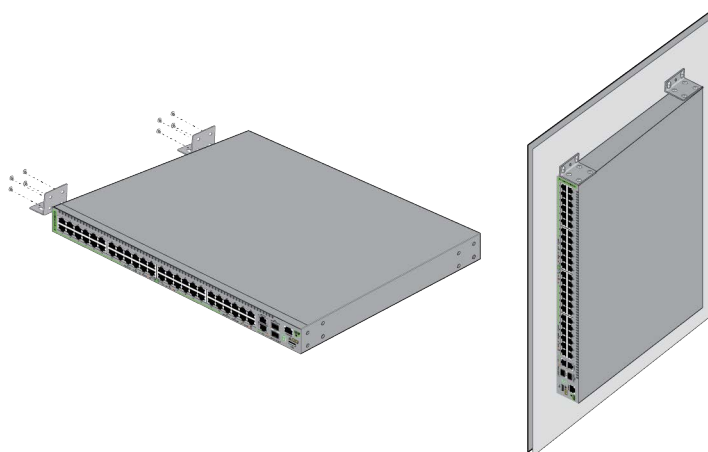

Figure 56. Attaching the Wall/Equipment Rack Brackets to the GS970EMX/52 Switch

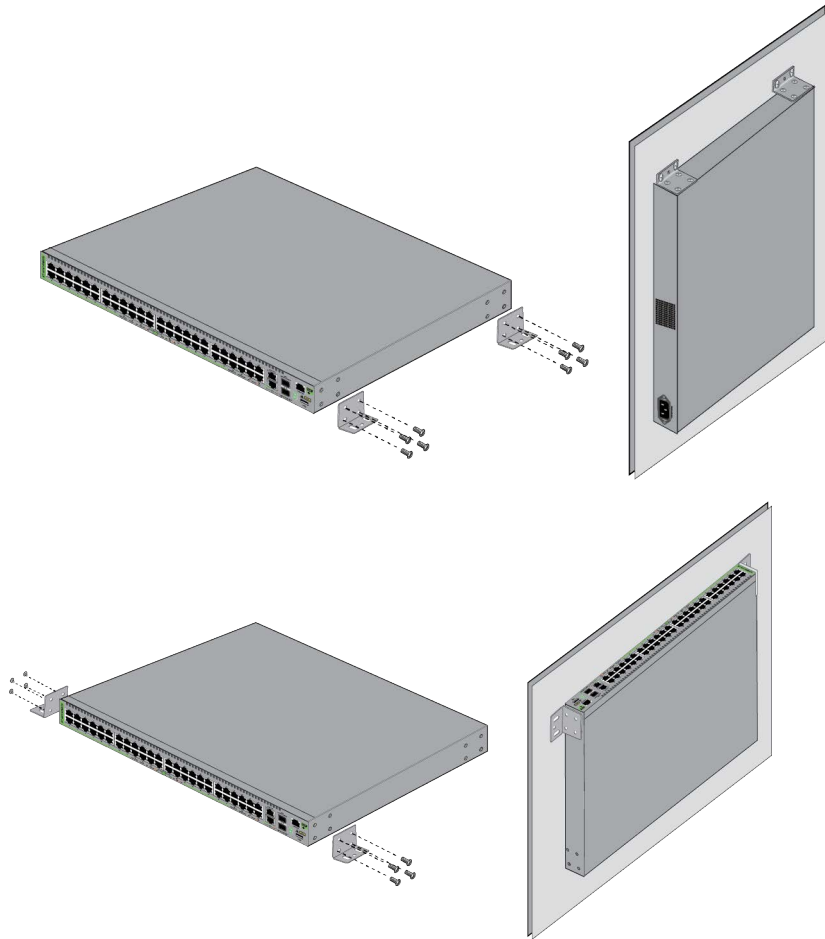

Figure 57. Attaching the Wall/Equipment Rack Brackets to the GS970EMX/52 Switch (continued)

Note

If the wall requires pre-drilled holes, such as a concrete wall, continue with the next step. Otherwise, go to step 8.

4. Have another person hold the switch on the concrete wall at the selected location for the device while you use a pencil or pen to mark the wall with the locations of the holes in the brackets. Refer to Figure 58 on page 108.

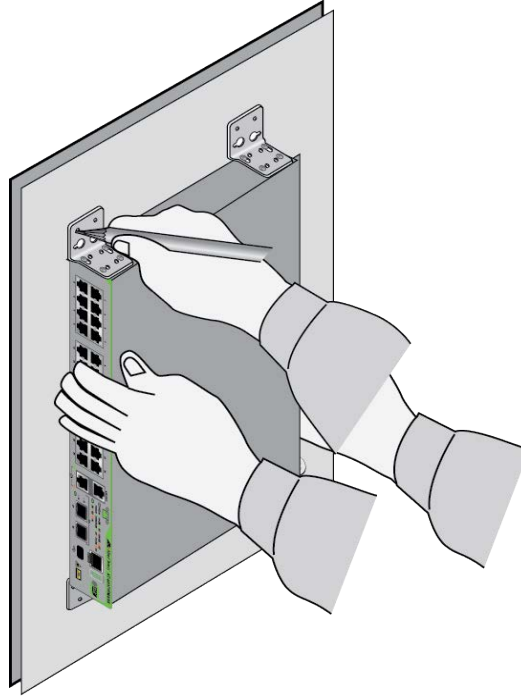

Figure 58. Marking the Locations of the Bracket Holes

5. Place the switch on a table or desk.
6. Use a drill and an appropriate drill bit, such as a 1/4" carbide drill bit for concrete walls, to pre-drill the holes you marked in step 4. Review the following guidelines:
 - ❑ For concrete walls, set the drill to hammer and rotation mode. The modes break up the concrete and clean out the hole.
 - ❑ Allied Telesis recommends cleaning out the holes with a brush or compressed air.
7. If the wall material requires anchors, insert appropriate anchors in the holes.
8. Have another person hold the switch on the wall while you secure it with appropriate screws.
9. Go to Chapter 8, "Displaying the Hardware Status and AlliedWare Plus Version Number" on page 109.

Chapter 8

Displaying the Hardware Status and AlliedWare Plus Version Number

The procedures in this chapter explain how to perform local management sessions on the switches to verify their hardware status and display the version numbers of the AlliedWare Plus management software. Allied Telesis recommends performing these procedures on each switch individually before building the stack. Here are the procedures:

- ❑ “Powering On the Switch” on page 110
- ❑ “Starting a Local Management Session” on page 112
- ❑ “Displaying the Hardware Status and AlliedWare Plus Version Number” on page 115

Powering On the Switch

The illustrations in this procedure show the North American power cord. Your power cord may look different. For AC power specifications, refer to “Power Specifications” on page 169.



Warning

Power cord is used as a disconnection device. To de-energize equipment, disconnect the power cord. ⚡ E3

Note

Pluggable Equipment. The socket outlet shall be installed near the equipment and shall be easily accessible. ⚡ E5

To power on the switch, perform the following procedure:

1. Install the power cord retaining clip on the AC power connector on the back panel of the switch. Refer to Figure 59.

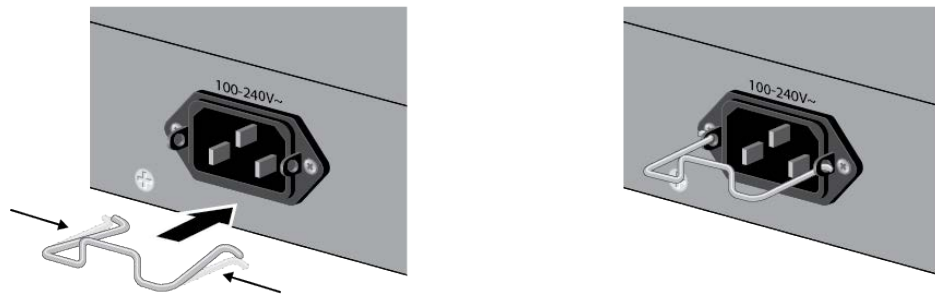

Figure 59. Installing the Power Cord Retaining Clip

2. Raise the retaining clip and connect the AC power cord to the AC power connector. Refer to Figure 60.

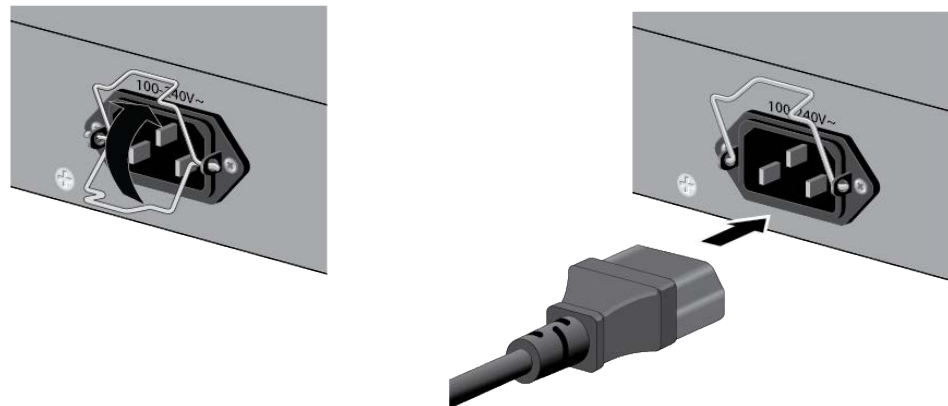

Figure 60. Connecting the AC Power Cord

3. Lower the retaining clip to secure the power cord to the switch. Refer to Figure 61.

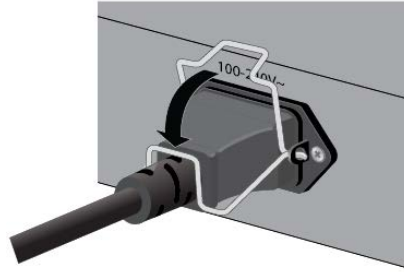

Figure 61. Lowering the Power Cord Retaining Clip

4. Connect the power cord to an appropriate AC power outlet. Refer to Figure 62.

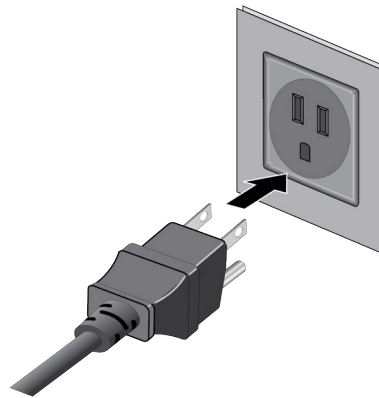

Figure 62. Connecting the Power Cord to an AC Power Outlet

5. Wait one minute for the switch to start the AlliedWare Plus management software
6. Go to “Starting a Local Management Session” on page 112:

Starting a Local Management Session

This section contains the procedure for starting a local management session on the switch through the Console port. This procedure requires a terminal, computer, or laptop with an RS-232 DB-9 serial port or USB port, and a terminal emulator, such as PuTTY. Here are the guidelines:

- ❑ Local management sessions require a management cable. If your computer has an RS-232 port, you may use the management cable supplied with the product, shown in Figure 63. The cable has a RJ-45 connector that connects to the Console port on the switch, and a female DB-9 (D-sub 9-pin) connector that connects to your computer.

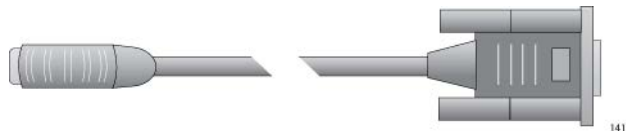

Figure 63. Management Cable Included with Switch

- ❑ If your computer has a USB port, you may need to purchase a USB-to-Serial converter that is compatible with its operating system. An example is the VT-Kit3 converter from Allied Telesis, shown in Figure 64. The VT-Kit3 converter is sold separately.



Figure 64. VT-Kit3 Management Cable

- ❑ Local management sessions do not interfere with the network operations of the switch.
- ❑ The switch does not need an IP address for local management sessions.

You can also manage the switch remotely over your network from your workstations. However, local management may be more convenient when configuring the switches for stacking. For remote management instructions, refer to the *GS970EMX Series Software Reference for AlliedWare Plus Operating System*.

To start a local management session, perform the following procedure:

1. Power on the switch and wait several minutes for it to initialize the AlliedWare Plus management software.
2. Connect your computer to the Console port on the switch:
 - If your computer has an RS-232 port, connect the DB-9 connector on the supplied management cable to a DB-9 port on your computer or terminal, and the cable's RJ-45 connector to the Console port on the switch.
 - If your computer has a USB port, use a USB-to-Serial converter. To use the VT-Kit3 from Allied Telesis, connect the USB connector on the VT-Kit3 to a USB port on your computer or terminal. To connect the kit to the Console port on the switch, use a standard, straight-through Ethernet cable. Refer to Figure 65.

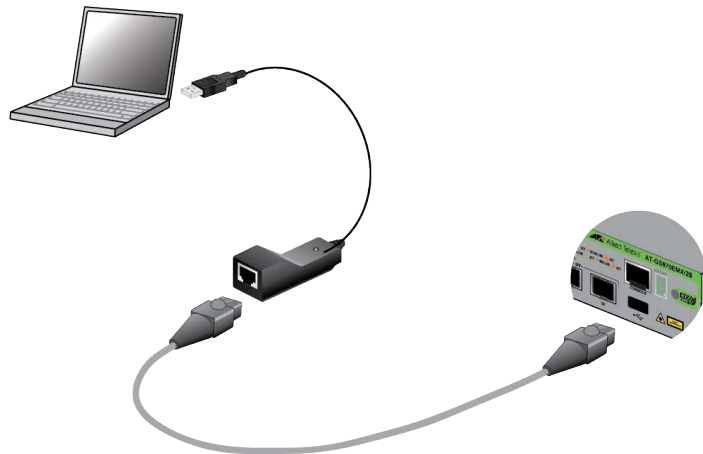

Figure 65. Local Management with the VT-Kit3 Management Cable

3. Configure the VT-100 terminal or terminal emulation program:
 - Baud rate: 9600 bps (The baud rate of the Console port is adjustable from 1200 to 115200 bps. The default is 9600 bps.)
 - Data bits: 8
 - Parity: None
 - Stop bits: 1
 - Flow controller: None

Note

The port settings are for a DEC VT100 or ANSI terminal, or an equivalent terminal emulator program.

Note

The baud rate must be set to the default 9600 bps to configure the boot loader.

4. Press Enter. You are prompted for the name and password of the manager account.
5. Enter the default user name “manager” and password “friend”, without the quotes.

Note

User names and passwords are case sensitive.

The switch starts the local management session and displays the following prompt:

```
awp1us>
```

The User Exec mode is the first level in the command mode interface of the AlliedWare Plus management software. For instructions, refer to the *Software Reference for GS970EMX Series Switches, AlliedWare Plus Operating System*.

6. Do one of the following:
 - ❑ To view the hardware status of the switch and AlliedWare Plus version number, go to “Displaying the Hardware Status and AlliedWare Plus Version Number” on page 115.
 - ❑ To configure the switch for stacking, go to Chapter 9, “Building Stacks with SFP+ Ports S1 and S2” on page 117 or Chapter 10, “Building Stacks with Multi-Gigabit Copper Ports” on page 127.

Displaying the Hardware Status and AlliedWare Plus Version Number

This section contains the procedure for displaying the version number of the AlliedWare Plus management software on the switch. All of the switches in a stack must have the same version of the management software. You should perform this procedure on the switches individually, before building the stack.

If you have already started a local management session on the switch, start with step 4. Otherwise, start with step 1. To view the management software version number, perform the following procedure:

1. Power on the switch. Refer to “Powering On the Switch” on page 110.
2. Wait one minute for the switch to start the AlliedWare Plus management software.
3. Start a local management session on the switch. Refer to “Starting a Local Management Session” on page 112.
4. In the User Exec or Privileged Exec mode, enter the `SHOW SYSTEM ENVIRONMENT` command. The components should have the status “OK” in the Status column of the screen output.
5. In the User Exec mode, enter either the `SHOW SYSTEM` or `SHOW VERSION` command.
6. Write down the Software Version value from the screen output in the Firmware Version Number column in the “VCStack Worksheet” on page 60.
7. If you need to upgrade the software on the switch, refer to the *Software Reference for GS970EMX Series Switches, AlliedWare Operating System* at www.alliedtelesis.com.
8. Power off the switch by disconnecting its AC power cord from the AC power source. Refer to Figure 66.

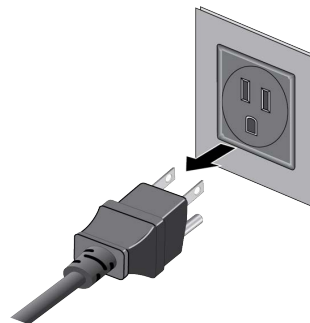

Figure 66. Disconnecting the Power Cord from the AC Power Source



Warning

Power cord is used as a disconnection device. To de-energize equipment, disconnect the power cord. *See* E3

9. Repeat the procedures in this chapter on the remaining switches that will be in the stack.
10. If there are no further switches, go to one of the following chapters:
 - ❑ Chapter 9, “Building Stacks with SFP+ Ports S1 and S2” on page 117
 - ❑ Chapter 10, “Building Stacks with Multi-Gigabit Copper Ports” on page 127

Chapter 9

Building Stacks with SFP+ Ports S1 and S2

This chapter contains the following procedures:

- ❑ “Introduction” on page 118
- ❑ “Powering On the Switches Sequentially” on page 119
- ❑ “Powering On the Switches Simultaneously” on page 121
- ❑ “Verifying the Stack and Assigning Priority Numbers” on page 123

Introduction

This chapter explains how to build the stack with SFP+ ports S1 and S2 as the stack trunk. There are no configuration procedures. The stacking feature is enabled by default on the switches and the SFP+ ports are the default trunk ports. To build the stack, you cable the trunk ports and power on the switches, either sequentially or simultaneously.

As explained in the following procedures, the switches are assigned ID numbers based on how you power on the devices. The switches display their ID numbers on the ID LEDs on the front panels and store them in their stack configuration files to identify their parameter settings. As explained in “Specifying Ports in the Command Line Interface” on page 58, you use the ID numbers to identify the switches when you configure them with the command line interface in the AlliedWare Plus management software. They retain their ID numbers even when you power off or reset the stack.

Here are the two procedures for powering on the stack with SFP+ ports S1 and S2 as the stack trunk:

- ❑ To control the assignment of the switch ID numbers yourself, perform “Powering On the Switches Sequentially” on page 119. The numbers are assigned in the order in which you power on the units.
- ❑ To have the switches assign the ID numbers automatically, perform “Powering On the Switches Simultaneously” on page 121.



Caution

Do not change the switch ID numbers after configuring the parameter settings of the stack. Otherwise, the stack might assign configuration settings to the wrong switches.

Note

To use the Multi-Gigabit copper ports as the stack trunk instead, refer to Chapter 10, “Building Stacks with Multi-Gigabit Copper Ports” on page 127. For background information, refer to “Multi-Gigabit Copper Ports” on page 49.

Powering On the Switches Sequentially

This procedure explains how to control the assignment of the switch ID numbers by powering on the units one at a time during the first power-on sequence. The first switch is assigned ID number 1, the next unit ID number 2, and so on. This procedure is useful when the switches are installed in the same equipment rack because you can number them in sequence, such as from top to bottom, making them easier to identify.

In this procedure, the first switch powered on becomes the master switch of the stack. If you do not change the priority values of the switches and later reset or power cycle the stack, the switches will select the master based on their MAC addresses. This could result in a different switch becoming the master switch of the stack. However, this does not change their ID numbers, the stack configuration, or the manner in which you manage the stack.

This procedure assumes the following:

- You performed “Displaying the Hardware Status and AlliedWare Plus Version Number” on page 115 to confirm that all the switches have the same version of the AlliedWare Plus management software.
- This is the first power-on of the stack.
- The switches are powered off.

You can monitor the power-on sequence by connecting a terminal or workstation with a terminal emulator program to the Console port on the switch you power on first. For the terminal settings, refer to “Starting a Local Management Session” on page 112.

Note

Refer to “Power Specifications” on page 169 for the power specifications of the switches.

To control the assignment of the ID numbers to the switches, perform the following procedure:

1. Cable the SFP+ ports S1 and S2 on all the switches of the stack. For guidelines and examples, refer to “SFP+ Ports S1 and S2” on page 46. For cabling instructions, refer to Chapter 11, “Cabling Copper and SFP+ Ports” on page 149.
2. Power on the switch you want assigned ID number 1. Refer to “Powering On the Switch” on page 110.



Warning

Power cord is used as a disconnection device. To de-energize equipment, disconnect the power cord. *See* E3

3. Wait one minute for the switch to start the AlliedWare Plus management software.

The switch displays the number 1 on its ID LED and is now the master switch.

4. Power on the switch to be assigned ID number 2.
5. Wait two minutes for the new switch to join the stack as a member.

The new switch automatically boots up twice before joining the stack as a new member, once with the default ID number 1 and again with the next available number, which is 2.

6. If there is a third switch, power it on and wait two minutes for it to join the stack as a member with the ID number 3.

7. Repeat step 6 until all the switches are powered on.

The stack is now operational. The switches retain their ID numbers even when reset or powered off.

8. To continue with the installation, go to “Verifying the Stack and Assigning Priority Numbers” on page 123.

Powering On the Switches Simultaneously

You can let the switches assign their ID numbers automatically by powering them on simultaneously during the first power-on sequence. They perform the following steps when assigning their ID numbers:

1. After starting their AlliedWare Plus management software, they compare their switch priority numbers over the stack trunk of the SFP+ ports S1 and S2.
2. Since they all have the same priority number, the default 128, they compare MAC addresses.
3. The switch with the lowest MAC address becomes the master switch.
4. The master switch assigns itself the ID number 1.
5. The master switch assigns ID numbers in the range of 2 to 4 to the other switches.
6. The other switches reboot the AlliedWare Plus management software with their new ID numbers.

This procedure assumes the following:

- You performed “Displaying the Hardware Status and AlliedWare Plus Version Number” on page 115 to confirm that all the switches have the same version of the AlliedWare Plus management software.
- This is the first power-on of the stack.
- All switches are powered off.

You can monitor the power-on sequence by connecting a terminal or workstation with a terminal emulator program to the Console port on any of the switches. For the terminal settings, refer to “Starting a Local Management Session” on page 112.

Note

Refer to “Power Specifications” on page 169 for the power specifications of the switches.

To have the switches assign the ID numbers automatically, perform the following procedure:

1. Cable the SFP+ ports S1 and S2 ports on the switches of the stack. For guidelines and examples, refer to “SFP+ Ports S1 and S2” on page 46. For cabling instructions, refer to Chapter 11, “Cabling Copper and SFP+ Ports” on page 149.

2. Power on all the switches of the stack simultaneously. Refer to “Powering On the Switch” on page 110.



Warning

Power cord is used as a disconnection device. To de-energize equipment, disconnect the power cord. *GE* E3

3. Wait three minutes for the switches to form the stack. They select the master switch, which assigns itself the ID number 1 and ID numbers 2 to 4 to the member switches.

The stack is now operational. The switches retain their ID numbers even when reset or powered off.

4. To continue with the installation, go to “Verifying the Stack and Assigning Priority Numbers” on page 123.

Verifying the Stack and Assigning Priority Numbers

To verify the stack and assign priority numbers, perform the following procedure:

1. Start a local management session on any switch in the stack. For instructions, refer to “Starting a Local Management Session” on page 112.
2. From the User Exec mode, enter the SHOW STACK command:

```
awplus> show stack
```

Figure 67 is an example of a stack of four switches.

```
awplus> show stack
Virtual Chassis Stacking summary information
ID      Pending ID  MAC address      Priority  Status  Role
1       -            nnnn:nnnn:nnnn  128     Ready   Active Master
2       -            nnnn:nnnn:nnnn  128     Ready   Backup Member
3       -            nnnn:nnnn:nnnn  128     Ready   Backup Member
4       -            nnnn:nnnn:nnnn  128     Ready   Backup Member
Operational Status      Normal operations
Stack MAC address       nnnn:nnnn:nnnn
awplus(config)#
```

Figure 67. SHOW STACK Command

Review the following items:

- ❑ The command should list all the switches in the stack. If the list is incomplete, refer to Chapter 12, “Troubleshooting” on page 157.
- ❑ The Operational Status field displays “Normal operations” when the stacking ports are cabled in the loop topology and all stacking ports are operating normally.
- ❑ The Operational Status field displays “Not all stack ports are up” if the trunk ports are in the chain topology or trunk ports are unable to establish links with their local or remote counterparts. Refer to Chapter 12, “Troubleshooting” on page 157.
- ❑ The priority numbers will be at the default 128. To change them to match the switch ID numbers, continue with this procedure.
- ❑ Depending on how you power on or reboot the stack in the future, the switches might select a different master switch when forming the stack. However, this does not change their ID numbers, their configurations, or the manner in which you manage the stack.

3. Do one of the following:
 - ❑ To set the switch priority values, continue with the next step. Setting the priority values is optional. For background information, refer to the “STACK PRIORITY Command” on page 130.
 - ❑ Otherwise, go to Chapter 11, “Cabling Copper and SFP+ Ports” on page 149, to complete the installation.

Note

Setting the priority values can protect the stack’s configuration if you later add a new switch that has a lower MAC address than the active master while the stack is powered off. If the priority values of the switches are at the default value when you power on the stack, the new switch will become the master, possibly resulting in the loss of the stack’s configuration.

4. Enter the ENABLE and CONFIGURE TERMINAL commands to move to the Privileged Exec mode: Refer to Figure 68.

```
awplus> enable
awplus# configure terminal
Enter configuration commands, one per line. End with CNTL/Z.
awplus(config)#
```

Figure 68. Moving to the Global Configuration Mode with the ENABLE and CONFIGURE TERMINAL Commands

5. Enter the STACK PRIORITY command to set the priority numbers. The command has this format:

```
stack ID_number priority priority
```

You can change the priority number of only one switch at a time. The parameters are as follows:

- ❑ The ID_NUMBER parameter is the ID number of the switch whose priority value you are setting. The range is 1 to 4. Switches display their ID numbers on the ID LEDs on the front panels.
- ❑ The PRIORITY parameter is the new priority value for the switch. The range is 0 to 255. The default is 128. The lower the number, the higher the priority.

The stack may be easier to manage if you make the priority numbers the same as the switch IDs. Here are two examples. To assign the priority value 1 to the switch with the ID number 1, you enter:

```
awplus(config)# stack 1 priority 1
```

To assign the priority value to 2 to the switch with the ID number 2, you enter:

```
awplus(config)# stack 2 priority 2
```

- After setting the priority values, enter the EXIT command to return to the Privileged Exec mode. Refer to Figure 69.

```
awplus(config)# exit
awplus#
```

Figure 69. Returning to the Privileged Exec Mode

- Enter the WRITE command to save your changes in the configuration file of the stack. The switch displays the confirmation prompt in Figure 70.

```
awplus# write
Building configuration ...
[OK]
awplus#
```

Figure 70. Saving the Priority Values with the WRITE Command

- Enter the SHOW STACK command to verify the new priority values. Figure 71 is an example.

```
awplus# show stack
Virtual Chassis Stacking summary information
```

ID	Pending ID	MAC address	Priority	Status	Role
1	-	nnnn:nnnn:nnnn	1	Ready	Active Master
2	-	nnnn:nnnn:nnnn	2	Ready	Backup Member
3	-	nnnn:nnnn:nnnn	3	Ready	Backup Member
4	-	nnnn:nnnn:nnnn	4	Ready	Backup Member

```
Operational Status          Normal operations
Stack MAC address           nnnn:nnnn:nnnn
```

Figure 71. SHOW STACK Command with New Switch Priority Values

- To end the management session, enter the EXIT command.
- Go to Chapter 11, “Cabling Copper and SFP+ Ports” on page 149, to complete the installation.

Chapter 10

Building Stacks with Multi-Gigabit Copper Ports

This chapter contains the following sections:

- ❑ “Introduction” on page 128
- ❑ “Command Summary” on page 129
- ❑ “Configuring the Master Switch” on page 133
- ❑ “Configuring Member Switches” on page 141
- ❑ “Powering On the Stack” on page 148

Introduction

As explained in “Stack Trunks” on page 46, the switches of a stack are connected by a physical link of two ports on each unit. There are two ways to build the trunk on GS970EMX Switches. One way is with the SFP+ ports S1 and S2, the default trunk ports. Those ports have the advantage of supporting short and long distance fiber optic transceivers, making it possible to build stacks of switches over large distances. For directions, refer to Chapter 9, “Building Stacks with SFP+ Ports S1 and S2” on page 117.

When the switches are physically close to each other, such as in the same building or equipment rack, you can use the Multi-Gigabit copper ports for the trunk instead, and reserve the SFP+ ports for other functions. As explained in this chapter, using the Multi-Gigabit copper ports as the trunk requires configuring the individual switches before building the stack. Here are the main steps:

1. Filling in the “VCStack Worksheet” on page 60.
2. Reviewing “Command Summary” on page 129.
3. “Configuring the Master Switch” on page 133.
4. “Configuring Member Switches” on page 141.
5. “Powering On the Stack” on page 148
6. “Verifying the Stack and Assigning Priority Numbers” on page 123

Review the following information before performing the instructions:

- The procedures should be performed in the order presented here.
- The master switch can be any GS970EMX Switch, except the GS970EMX/10 Switch, which does not support the VCStack feature. Refer to “Master and Member Switches” on page 54.
- If network cables are connected to the Multi-Gigabit copper ports, disconnect them before continuing. You should configure the switches before cabling the trunk ports.

Note

Cabling the ports of the stack trunk before configuring the switches may result in loops in your network topology, which can cause poor network performance.

Command Summary

This section describes the AlliedWare Plus commands for configuring the Multi-Gigabit copper ports as the stack trunk on the master and member switches. For further instructions, refer to the *Software Reference for GS970EMX Switch, AlliedWare Plus Operating System*. After reviewing the commands, start the configuration procedures by performing “Configuring the Master Switch” on page 133.

STACK ENABLE Command

You use this command to enable and disable the VCStack feature on switches. Located in the Global Configuration mode of the AlliedWare Plus management software, the command has these two forms:

- ❑ **STACK ENABLE:** This command enables VCStack on switches. This is the default setting.
- ❑ **NO STACK ENABLE:** This command disables VCStack. You may disable the feature to use switches as standalone units.

Here is an example of the STACK ENABLE command:

```
awplus(config)# stack enable
```

Here is the format of the NO STACK ENABLE command:

```
no stack stack-ID enable
```

The stack-ID variable is the ID number of the switch where you want to disable stacking. The ID number is displayed on the switch’s ID LED on the front panel. This example disables VCStack on the switch with the ID 4:

```
awplus(config)# no stack 4 enable
```

STACKPORT Command

You use this command to select and deselect the ports of the stack trunk. Located in the port interface modes, the command has these two forms:

- ❑ **STACKPORT:** This command designates ports as the stack trunk. This is the default setting for the SFP+ ports.
- ❑ **NO STACKPORT:** This command deselects ports from the stack trunk and defines them as regular Ethernet ports. This is the default setting for the Multi-Gigabit copper ports.

To use the Multi-Gigabit copper ports as the stack trunk, you first need to remove the SFP+ ports from the trunk and define them as regular Ethernet ports. This is performed with the NO version of the command. This example of the command removes SFP+ 27/S1 and 28/S2 ports as trunk ports on the GS970EMX/28 Switch with ID number 1:

```
awplus(config)# interface port1.0.27-1.0.28
awplus(config-if)# no stackport
```

After removing the SFP+ as the stack trunk, you can designate the Multi-Gigabit copper ports as the trunk, as in this example also for the GS970EMX/28 Switch:

```
awplus(config)# interface port1.0.25-1.0.26
awplus(config-if)# stackport
```

STACK PRIORITY Command

You use this command to set a switch's priority value. The range is 0 to 255. The default is 128. The lower the number, the higher the priority. Switches use their priority settings for the following functions:

- ❑ Select the master switch when the switches are powered on or rebooted simultaneously.
- ❑ Designate the order in which they become the master switch if the active master switch stops responding.

If the switches have the same priority value, they use their MAC addresses to select the master. The lower the MAC address, the higher the priority.

Allied Telesis recommends setting the priority numbers to match the switch ID numbers. For example, the switch with ID 1 should be assigned priority 1, switch with ID 2 should be assigned priority 2, and so on. This is not a requirement, but it can make it easier to manage the stack.

Note

Setting the priority values can protect the stack's configuration if you later add a new switch that has a lower MAC address than the active master while the stack is powered off. If the priority values of the switches are at the default value when you power on the stack, the new switch will become the master, possibly resulting in the loss of the stack's configuration.

The command has this format:

```
stack switch_ID priority priority_number
```

The variables are defined here:

- ❑ *switch_ID* - This is the ID number of the switch. The ID number is displayed on the ID LED on the front panel. The range is 1 to 4. You can specify only one ID number.
- ❑ *priority_number* - This is the new priority number for the switch. The range is 0 to 255. The default is 128. You can specify only one number.

This example assigns the priority 1 to the switch with ID 1:

```
awplus(config)# stack 1 priority 1
```

This example assigns the priority 2 to the switch with ID 2:

```
awplus(config)# stack 2 priority 2
```

STACK RENUMBER Command

Every switch in the stack must have a unique ID number. The switches display their numbers on the ID LEDs on the front panels. The range is 1 to 4. The default is 1. You use the numbers to identify switches when configuring their parameter settings with the AlliedWare Plus management software. Refer to “Specifying Ports in the Command Line Interface” on page 58.

The master switch can assign the ID numbers automatically to the member switches during the first power-on of the stack, or you can use this command to set them either before or immediately after building the stack. Found in the Global Configuration mode, the command has this format.

```
stack current_switch_ID renumber new_switch_ID
```

The variables are defined here:

- ❑ *current_switch_ID* - This is the current ID number of the switch. You can specify only one ID number.
- ❑ *new_switch_ID* - This is the new ID number for the switch. The range is 1 to 4. The default is 1. You can specify only one number.

Changing the ID number requires resetting the switch.

This example changes a switch’s current ID from 1, the default, to 2:

```
awplus(config)# stack 1 renumber 2
```

Note

Do not change the ID numbers of the switches after configuring their parameter settings. Otherwise, the master switch might assign parameter settings to the wrong switches the next time you power on or reset the stack.

Note

Switches use their priority numbers and MAC addresses, not their ID numbers, to select the master switch. Consequently, the master switch of the stack can have any ID number.

SWITCH PROVISION Command

You use this command to add member switches to the configuration of the master switch before powering on the stack for the first time. Here are the command guidelines:

- ❑ Adding member switches to the master switch is not required when using the default SFP+ S1 and S2 ports as the stack trunk.
- ❑ Adding member switches to the master switch is required when using the Multi-Gigabit copper ports as the trunk.
- ❑ You have to add one provisioned member switch for each physical member switch to be in the stack. For example, if the stack will have three member switches, then you have to add three provisioned switches to the master switch.
- ❑ You can add only one member switch at a time with the command.

Here is the format of the command:

```
switch switch_ID provision GS970EMX-20|GS970EMX-28|  
GS970EMX-52
```

This example adds a GS970EMX/20 Switch as a provisioned member switch with the ID 2 to the master switch:

```
awplus(config)# switch 2 provision GS970EMX-20
```

This example adds a GS970EMX/28 Switch as a provisioned member switch with the ID 3 to the master switch:

```
awplus(config)# switch 3 provision GS970EMX-28
```

This example adds a GS970EMX/52 Switch as a provisioned member switch with the ID 4 to the master switch:

```
awplus(config)# switch 4 provision GS970EMX-52
```

Configuring the Master Switch

This section contains the procedures for configuring GS970EMX Switches as the master switch of the stack. The procedures designate the Multi-Gigabit copper ports as the stack trunk and add the member switches as provisioned switches.

Note

Any GS970EMX/20, GS970EMX/28, or GS970EMX/52 Switch can be the master switch of the stack.

Here are the procedures:

- ❑ “General Steps for the Master Switch,” next
- ❑ “Configuring the Master Switch - Part I” on page 134
- ❑ “Configuring the Master Switch - Part II” on page 136
- ❑ “Verifying the Master Switch” on page 138
- ❑ “What to Do Next” on page 140

The procedures should be performed in the order presented here.

Note

The procedures require resetting the switch. Some network traffic will be lost if its ports are already connected to active devices.

Allied Telesis recommends filling out the “VCStack Worksheet” on page 60 before building the stack.

General Steps for the Master Switch

There are two parts to designating the Multi-Gigabit copper ports on the master switch as the stack trunk. Here are the main steps to Part I:

1. Start a local management session on the switch.
2. Remove the stacking function from the default SFP+ S1 and S2 ports with the NO STACKPORT command.
3. Designate the Multi-Gigabit copper ports as the stack trunk with the STACKPORT command.
4. Assign the master switch the priority 1 with the STACK PRIORITY command in the Global Configuration mode to designate it as the master switch of the stack.
5. Save your changes with the WRITE command in the Privilege Exec mode.

Here are the main steps to Part II:

1. Add the member switches as provisioned units to the configuration of the master switch, with the SWITCH PROVISION command.
2. Remove the default SFP+ S1 and S2 ports from the stack trunk on the provisioned member switches with the NO STACKPORT command.
3. Designate the Multi-Gigabit copper ports as the stack trunk on the provisioned member switches, with the STACKPORT command.
4. Save your changes with the WRITE command in the Privilege Exec mode.
5. Reboot the master switch with the REBOOT command.
6. Start a new local management session.
7. Verify your changes with the SHOW STACK and SHOW RUNNING-CONFIG INTERFACE commands.

Configuring the Master Switch - Part I

To configure the master switch for a stack trunk of Multi-Gigabit copper ports, start by performing the procedure in Table 12.

Table 12. Configuring the Master Switch for a Stack Trunk of Multi-Gigabit Copper Ports - Part I

Step	Description and Command
1	Power on the master switch and wait one minute for it to start the AlliedWare Plus management software. Refer to “Powering On the Switch” on page 110.
2	Start a local management session. Refer to “Starting a Local Management Session” on page 112.
3	Enter the ENABLE and CONFIGURE TERMINAL commands to move to the Global Configuration mode. <pre>awplus> enable awplus# configure terminal</pre> Enter configuration commands, one per line. End with CNTL/Z.

Table 12. Configuring the Master Switch for a Stack Trunk of Multi-Gigabit Copper Ports - Part I

Step	Description and Command
Steps 4 and 5 use the NO STACKPORT command to remove the SFP+ S1 and S2 ports from the stack trunk and redefine them as regular networking ports.	
4	<p>Enter the Interface modes for the SFP+ S1 and S2 ports on the switch. This example assumes the switch is the 28-port GS970EMX/28 Switch:</p> <pre>awplus(config)# interface port1.0.27-1.0.28 % port1.0.27 is currently configured as a stack-port. Use caution when altering its config. % port1.0.28 is currently configured as a stack-port. Use caution when altering its config. awplus(config-if)#</pre>
5	<p>Enter the NO STACKPORT command to remove the ports from the trunk and designate them as regular networking ports:</p> <pre>awplus(config-if)# no stackport % Save the config and restart the system for this change to take effect.</pre>
Steps 6 and 7 enter the interface modes for the Multi-Gigabit copper ports, and designate them as the stack trunk with the STACKPORT command.	
6	<p>Enter the Interface mode for the Multi-Gigabit copper ports. This example assumes the switch is the 28-port GS970EMX/28 Switch:</p> <pre>awplus(config-if)# interface port1.0.25-1.0.26</pre>
7	<p>Enter the STACKPORT command to designate the ports as the stack trunk:</p> <pre>awplus(config-if)# stackport % Save the config and restart the system for this change to take effect.</pre>
Steps 8 and 9 assign the switch the priority 1 with the STACK PRIORITY command to designate it as the master unit of the stack.	
8	<p>Enter the EXIT command to return to the Global Configuration mode.</p> <pre>awplus(config-if)# exit</pre>
9	<p>Enter the STACK PRIORITY command to assign priority 1 to the switch.</p> <pre>awplus(config)# stack 1 priority 1</pre>

Table 12. Configuring the Master Switch for a Stack Trunk of Multi-Gigabit Copper Ports - Part I

Step	Description and Command
The remaining steps save your changes.	
10	Enter the EXIT command to return to the Privileged Exec mode. awplus(config)# exit
11	Enter the WRITE command to save your changes. awplus# write Building configuration ... [OK]
12	Go to “Configuring the Master Switch - Part II,” next.

Configuring the Master Switch - Part II

In this procedure, you add the member switches to the configuration of the master switch. This involves adding them as provisioned switches and identifying their Multi-Gigabit copper ports as the stack trunk. The procedure assumes you are continuing directly from the previous procedure.

Table 13. Configuring the Master Switch for a Stack Trunk of Multi-Gigabit Copper Ports - Part II

Step	Description and Command
Steps 1 to 2 add the member switches as provisioned switches to the master switch with the SWITCH PROVISION command.	
1	Enter the CONFIGURE TERMINAL command to move to the Global Configuration mode. awplus# configure terminal Enter configuration commands, one per line. End with CNTL/Z. awplus(config)#
2	Enter the SWITCH PROVISION command to add the member switches as provisioned switches to the configuration of the master switch. Assign each unit a unique ID number in the range of 2 to 4. These examples add one GS970EMX/20 Switch, one GS970EMX/28 Switch, and one GS970EMX/52 Switch as provisioned member switches to the master switch, with the IDs 2 to 4, respectively: awplus(config)# switch 2 provision GS970EMX-28 awplus(config)# switch 3 provision GS970EMX-28 awplus(config)# switch 4 provision GS970EMX-52

Table 13. Configuring the Master Switch for a Stack Trunk of Multi-Gigabit Copper Ports - Part II

Step	Description and Command
Steps 3 and 4 remove the default SFP+ S1 and S2 ports from the trunk on the provisioned member switches that you added in step 2, with the NO STACKPORT command.	
3	<p>Enter the port Interface modes of the SFP+ S1 and S2 ports in the provisioned member switches on the master switch. (Refer to “Specifying Ports in the Command Line Interface” on page 58.) This example assumes provisioned switches with IDs 2, 3, and 4 are GS970EMX/20, GS970EMX/28, and GS970EMX/52 Switches, respectively:</p> <pre>awplus(config)# interface port4.0.19-4.0.20,port2.0.27-2.0.28, port2.0.51-2.0.52</pre>
4	<p>Enter the NO STACKPORT command to remove the SFP+ S1 and S2 ports from the stack trunk and designate them as regular Ethernet ports:</p> <pre>awplus(config-if)# no stackport % Save the config and restart the system for this change to take effect.</pre>
Steps 5 and 6 use the STACKPORT command to designate the Multi-Gigabit copper ports as the stack trunk on the provisioned member switches on the master switch.	
5	<p>Enter the Interface modes of the Multi-Gigabit copper ports on the provisioned member switches in the master switch. This example assumes provisioned switches with IDs 2, 3, and 4 are GS970EMX/20, GS970EMX/28, and GS970EMX/52 Switches, respectively:</p> <pre>awplus(config)# port2.0.17-2.0.18,port3.0.25-3.0.26,port4.0.49-4.0.50</pre>
6	<p>Designate the ports as the stack trunk with the STACKPORT command.</p> <pre>awplus(config-if)# stackport % Save the config and restart the system for this change to take effect.</pre>
The remaining steps save your changes on the master switch and reboot it.	
7	<p>Enter the EXIT command twice to return to the Privileged Exec mode.</p> <pre>awplus(config-if)# exit awplus(config)# exit</pre>
8	<p>Enter the WRITE command to save your changes.</p> <pre>awplus# write Building configuration ... [OK]</pre>

Table 13. Configuring the Master Switch for a Stack Trunk of Multi-Gigabit Copper Ports - Part II

Step	Description and Command
9	Restart the switch with the REBOOT command. awplus# reboot reboot system? (y/n):
10	Type “Y” for yes.
11	Wait one minute for the switch to start the AlliedWare Plus software.
12	Go to “Verifying the Master Switch,” next.

Verifying the Master Switch

To confirm the configuration of the master switch, perform the following steps:

1. Start a new local management session on the master switch. Refer to “Starting a Local Management Session” on page 112.
2. Move to the Privileged Exec mode with the ENABLE command.

```
awplus> enable
awplus#
```

3. Enter the SHOW STACK command. Figure 72 is an example of a master switch with three provisioned member switches:

```
awplus# show stack
Virtual Chassis Stacking summary information
ID Pending ID  MAC address      Priority  Status  Role
1 -             nnnn.nnnn.nnnn   1        Ready   Active Master
2 -             -                -        -       Provisioned
3 -             -                -        -       Provisioned
4 -             -                -        -       Provisioned

Operational Status      standalone unit
Stack MAC address       nnnn.nnnn.nnnn
```

Figure 72. SHOW STACK Command on the Master Switch

4. Check the display for the following:
 - Switch ID 1 is the master switch.
 - The other ID entries are the provisioned member switches that you added. There should be one entry for each member switch that will be in the stack. If the table does not include these fields, repeat “Configuring the Master Switch - Part II” on page 136.

- ❑ The Operational Status should be Standalone Unit. This indicates that VCStack is enabled, but that the unit is operating as a stack of one switch. If the status is Stacking Hardware Disabled, VCStack is disabled.

Note

The default setting for VCStack is enabled. If VCStack is disabled, perform the STACK ENABLE command in the Global Configuration mode to enable it.

- ❑ The master switch should have the priority 1.
5. Enter the SHOW RUNNING-CONFIG INTERFACE command to view the port configurations of the master switch and the provisioned member switches. Verify that the Multi-Gigabit copper ports have the STACKPORT command, identifying them as the stack trunk. Refer to Figure 73 for an example.

```
awplus# show running-config interface
interface port1.0.1-1.0.23
  switchport
  switchport mode access
!
interface port1.0.25-1.0.26  ❑ Multi-Gigabit trunk
  stackport                  ports on a master
                              GS970EMX/28 Switch
!
interface port1.0.27-1.0.28
  switchport
  switchport mode access
!
interface port2.0.1-2.0.24
  switchport
  switchport mode access
!
interface port2.0.17-2.0.18 ❑ Multi-Gigabit trunk
  stackport                  ports on a provisioned
                              member GS970EMX/20
                              Switch
!
interface port2.0.19-2.0.20
  switchport
  switchport mode access
.
.
.
```

Figure 73. SHOW RUNNING-CONFIG INTERFACE Command on the Master Switch

6. Go to “What to Do Next” on page 140.

What to Do Next After configuring the master switch, do the following:

1. Power off the switch by disconnecting its AC power cord from the AC power source. Refer to Figure 74.

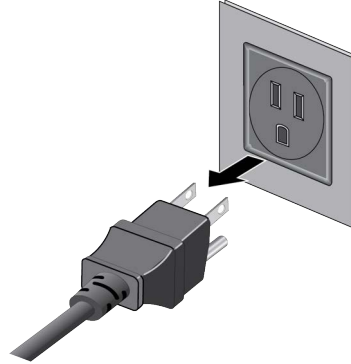

Figure 74. Powering Off the Switch

2. Configure the member switches. Refer to “Configuring Member Switches” on page 141.
3. After configuring the master switch and all member switches, cable the Multi-Gigabit copper ports on the switches. Refer to “Multi-Gigabit Copper Ports” on page 49 and “Cabling Copper Ports” on page 150.
4. Power on the master and member switches of the stack. Refer to “Powering On the Stack” on page 148.
5. Verify that the switches formed the stack by referring to “Verifying the Stack and Assigning Priority Numbers” on page 123.
6. Cable the networking ports. Refer to Chapter 11, “Cabling Copper and SFP+ Ports” on page 149.

Configuring Member Switches

This section contains the procedures for designating the Multi-Gigabit copper ports as the stack trunk for the member switches of a stack. Here are the procedures:

- ❑ “General Steps for Member Switches” on page 141
- ❑ “Configuring Member Switches - Part I” on page 142
- ❑ “Configuring Member Switches - Part II” on page 143
- ❑ “Verifying Member Switches” on page 145
- ❑ “What to Do Next for Member Switches” on page 147

You have to perform the procedures on each member switch individually, before connecting the trunk ports. The procedures should be performed in the order presented here.

Note

The procedures require resetting member switches. Some network traffic will be lost if the ports are connected to an active network.

General Steps for Member Switches

Configuring member switches has two parts. Here are the main steps to Part I:

1. Start a local management session on the switch.
2. Assign an ID number in the range of 2 to 4 to the member switch with the SWITCH RENUMBER command in the Global Configuration mode.
3. Save your changes with the WRITE command in the Privilege Exec mode.
4. Restart the switch with the REBOOT command.

Part II has these main steps:

1. Start a new local management session with the switch.
2. Remove SFP+ S1 and S2 ports from the stack trunk on the switch with the NO STACKPORT command.
3. Designate the Multi-Gigabit copper ports as the stack trunk with the STACKPORT command.
4. Save your changes with the WRITE command in the Privilege Exec mode.

5. Restart the switch with the REBOOT command.
6. Start a new local management session.
7. Verify your changes with the SHOW STACK and SHOW RUNNING-CONFIG INTERFACE commands.

Configuring Member Switches - Part I

Perform the procedure in Table 14 to perform Part I to configure a member switch.

Table 14. Configuring Member Switches - Part I

Step	Description and Command
1	Power on a member switch and wait one minute for it to start the AlliedWare Plus management software. Refer to “Powering On the Switch” on page 110.
2	Start a local management session. Refer to “Starting a Local Management Session” on page 112.
3	Enter the ENABLE and CONFIGURE TERMINAL commands to move to the Global Configuration mode: <pre>awplus> enable awplus# configure terminal Enter configuration commands, one per line. End with CNTL/Z. awplus(config)#</pre>
Step 4 sets the member switch’s ID number.	
4	Set the ID number of the member switch with the STACK RENUMBER command. Each switch must have a unique ID number. The default value is 1. If you are using the worksheet on “VCStack Worksheet” on page 60, refer there for the ID numbers. This example changes the switch’s ID number from the default value 1 to the new ID 2. <pre>awplus(config)# stack 1 renumber 2 % warning: the new ID will not become effective until the stack-member reboots. % warning: the boot configuration may now be invalid.</pre>
The remaining steps reboot the unit. (You do not have to update the configuration file with the WRITE command after changing a switch’s ID number.)	
5	Enter the EXIT command to return to the Privileged Exec mode. <pre>awplus(config)# exit</pre>

Table 14. Configuring Member Switches - Part I (Continued)

Step	Description and Command
6	Restart the switch with the REBOOT command. awplus# reboot reboot system? (y/n): awplus#
7	Type “Y” for yes.
8	Wait one minute for the switch to start the AlliedWare Plus software.
9	Check the ID LED on the front panel. Do one of the following: - If the ID LED is displaying the switch’s new ID number, go to “Configuring Member Switches - Part II,” next. - If the ID LED is displaying the wrong number, repeat this procedure.

Configuring Member Switches - Part II

Part II has these steps:

- Remove SFP+ S1 and S2 ports as the stack trunk.
- Designate the Multi-Gigabit copper ports as the stack trunk.
- Reboot the switch.

Perform the procedure in Table 15.

Table 15. Configuring Member Switches - Part II

Step	Description and Command
1	Start a new local management session on the member switch. Refer to “Starting a Local Management Session” on page 112.
2	Enter the ENABLE and CONFIGURE TERMINAL commands to move to the Global Configuration mode. awplus> enable awplus# configure terminal Enter configuration commands, one per line. End with CNTL/Z. awplus(config)#
Steps 3 and 4 remove the SFP+ S1 and S2 ports from the stack trunk on the member switch.	

Table 15. Configuring Member Switches - Part II (Continued)

Step	Description and Command
3	<p>Enter the port Interface modes of the SFP+ S1 and S2 ports on the member switch. When specifying the ID number of the switch in the PORT parameter, be sure to use the ID number you assigned it in Part I. This example assumes the member switch is the 28-port GS970EMX/28 Switch, with the ID 2:</p> <pre>awplus(config)# interface port2.0.27-2.0.28 % port2.0.27 is currently configured as a stack-port. Use caution when altering its config. % port2.0.28 is currently configured as a stack-port. Use caution when altering its config.</pre>
4	<p>Enter the NO STACKPORT command to remove the ports from the stack trunk and define them as regular Ethernet ports:</p> <pre>awplus(config-if)# no stackport % Save the config and restart the system for this change to take effect.</pre>
Steps 5 and 6 designate the Multi-Gigabit copper ports as the stack trunk.	
5	<p>Enter the Interface modes of the Multi-Gigabit copper ports on the member switch. This example again assumes the member switch is a GS970EMX/28 Switch with ID number 2:</p> <pre>awplus(config-if)# interface port2.0.25-2.0.26</pre>
6	<p>Designate the ports as the stack trunk with the STACKPORT command.</p> <pre>awplus(config-if)# stackport % Save the config and restart the system for this change to take effect.</pre>
The remaining steps save your changes and reboot the switch.	
7	<p>Enter the EXIT command twice to return to the Privilege Exec mode.</p> <pre>awplus(config-if)# exit awplus(config)# exit awplus#</pre>
8	<p>Save your changes with the WRITE command.</p> <pre>awplus# write Building configuration ... [OK]</pre>
9	<p>Reboot the switch.</p> <pre>awplus# reboot reboot system? (y/n):</pre>

Table 15. Configuring Member Switches - Part II (Continued)

Step	Description and Command
10	Type "Y" for yes.
11	Wait one minute for the switch to start the AlliedWare Plus software.
12	Go to "Verifying Member Switches," next.

Verifying Member Switches

Perform this procedure to verify the configuration of a member switch.

1. Start a new local management session on the switch. Refer to "Starting a Local Management Session" on page 112.
2. Move to the Privileged Exec mode with the ENABLE command.

```
awplus> enable
awplus#
```

3. Enter the SHOW STACK command. Figure 75 is an example of a member switch with the ID number 2.

```
awplus# show stack
Virtual Chassis Stacking summary information
ID Pending ID  MAC address          Priority  Status  Role
1  -            -                    128     -       Provisioned
2  -            nnnn.nnnn.nnnn    128     Ready   Active Master
Operational status      Standalone unit
Stack MAC address      nnnn.nnnn.nnnn
```

Figure 75. SHOW STACK Command for a Member Switch

4. Check the display for the following:
 - The values for the ID 1 row should be blank. This default provisioned entry will be used by the master switch when you power on the stack.
 - The member's Switch ID should be the number you assigned it in Part I.
 - The Operational Status should be Standalone Unit, indicating that VCStack is enabled and that the unit is operating as a stack of one switch. If the status is Stacking Hardware Disabled, VCStack is disabled.

Note

The default setting for VCStack is enabled. If VCStack is disabled, perform the STACK ENABLE command in the Global Configuration mode to enable it.

5. Enter the SHOW RUNNING-CONFIG INTERFACE command to display the port configuration on the member switch. Confirm that the Multi-Gigabit copper ports for the member switch have the STACKPORT command, designating them as the trunk. Figure 76 is an example from the GS970EMX/28 Switch.

```
awplus# show running-config interface
interface port1.0.1-1.0.26
  switchport
  switchport mode access
!
interface port1.0.27-1.0.28   #1
  stackport
!
interface port2.0.1-2.0.24
  switchport
  switchport mode access
!
interface port2.0.25-2.0.26   #2
  stackport
!
interface port2.0.27-2.0.28
  switchport
  switchport mode access
!
awplus#
```

Figure 76. SHOW RUNNING-CONFIG INTERFACE Command for Member Switches

Note the following:

- ❑ #1 - These lines with the STACKPORT command designate the stack ports for the default provisioned switch. You can ignore these lines on member switches.
- ❑ #2 - These lines with the STACKPORT command designate the trunk ports for the member switch you are configuring. The switch ID number in the PORT parameter should match the ID number of the switch and the port numbers should be the Multi-Gigabit copper ports. Repeat the procedure if the display does not include these lines.

6. Go to “What to Do Next for Member Switches” on page 147.

What to Do Next for Member Switches

After configuring a member switch, do the following:

1. Power off the member switch by disconnecting its AC power cord from the AC power source. Refer to Figure 74 on page 140.
2. Repeat these procedures to configure all member switches, assigning them unique ID numbers and designating the Multi-Gigabit copper ports as the stack trunk.
3. If you have not already configured the master switch, perform “Configuring the Master Switch” on page 133.
4. Power off the master and all member switches.
5. Cable the Multi-Gigabit copper ports on the master and member switches. For trunk cabling examples, refer to “Multi-Gigabit Copper Ports” on page 49. Refer to “Cabling Copper Ports” on page 150.
6. Perform “Powering On the Stack” on page 148.
7. Perform “Verifying the Stack and Assigning Priority Numbers” on page 123 to confirm that the switches formed the stack.
8. Cable the networking ports, as explained in Chapter 11, “Cabling Copper and SFP+ Ports” on page 149.

Powering On the Stack

After designating the Multi-Gigabit copper ports on the master and member switches as the stack trunk and assigning them ID numbers, you are ready to cable the trunk ports and power on the stack. You can monitor the power-on sequence by connecting a terminal or computer with a terminal emulator program to the Console port on the master switch. The terminal settings are listed in “Starting a Local Management Session” on page 112.

To power on the stack for the first time, perform the following procedure:

1. Verify that the master and member switches are powered off.
2. Cable the Multi-Gigabit copper ports of the stack trunk on the switches. For trunk examples, refer to “Multi-Gigabit Copper Ports” on page 49. Refer to “Cabling Copper Ports” on page 150.
3. Power on the master switch. Refer to “Powering On the Switch” on page 110.

Refer to “Power Specifications” on page 169 for the power specifications of the switches.



Warning

Power cord is used as a disconnection device. To de-energize equipment, disconnect the power cord. *GE* E3

Note

Pluggable Equipment. The socket outlet shall be installed near the equipment and shall be easily accessible. *GE* E5

4. Wait one minute for the master switch to start the AlliedWare Plus management software.
5. Power on the member switches either sequentially or simultaneously.
6. Wait two minutes for the member switches to join the stack.
7. Go to “Verifying the Stack and Assigning Priority Numbers” on page 123.

Chapter 11

Cabling Copper and SFP+ Ports

This chapter contains the following sections:

- ❑ “Cabling Copper Ports” on page 150
- ❑ “Guidelines to Handling SFP and SFP+ Transceivers” on page 151
- ❑ “Installing 1Gbps SFP and 10Gbps SFP+ Transceivers” on page 152
- ❑ “Installing SP10TW Direct Connect Twinax Cables in SFP+ Ports” on page 155

Cabling Copper Ports

Here are the guidelines to cabling the copper ports:

- ❑ The cable specifications are in “10/100/1000Mbps Copper Ports” on page 26 and “1/2.5/5/10Gbps Multi-Gigabit Copper Ports” on page 28.
- ❑ The connectors on the cables should fit snugly into the ports, and the tabs should lock the connectors into place.
- ❑ The default speed setting for the ports is Auto-Negotiation. This setting is appropriate for ports connected to network devices that also support Auto-Negotiation.
- ❑ Ports must be set to Auto-Negotiation, the default setting, to operate at 1000Mbps and higher speeds.
- ❑ The ports support full-duplex only at 1000Mbps and higher speeds.
- ❑ Do not attach cables to ports of static or LACP port trunks until after configuring the trunks on the switch. Otherwise, the ports might form network loops that can adversely affect network performance.

Guidelines to Handling SFP and SFP+ Transceivers

Review the following guidelines before installing SFP and SFP+ transceivers in the switch:

- ❑ Transceivers are hot-swappable. You can install them while the switch is powered on.
- ❑ For a list of supported transceivers, refer to the product's data sheet on the Allied Telesis web site.
- ❑ The operational specifications and fiber optic cable requirements of the transceivers are provided in documents included with the devices.
- ❑ You should install a transceiver before connecting its fiber optic cable.
- ❑ Fiber optic transceivers are dust sensitive. Always keep the plug in the optical bores when a fiber optic cable is not installed, or when you store the transceiver. When you do remove the plug, keep it for future use.
- ❑ Unnecessary removal and insertion of transceivers can lead to their premature failures.



Caution

Transceivers can be damaged by static electricity. Be sure to observe all standard electrostatic discharge (ESD) precautions, such as wearing an anti-static wrist strap, to avoid damaging the devices. *ES* E92

Installing 1Gbps SFP and 10Gbps SFP+ Transceivers

This section contains installation instructions for SFP and SFP+ transceivers. The transceiver in the illustrations has a duplex LC connector. Your transceivers may have different connectors. To install transceivers, perform the following procedure:

1. Select an SFP+ port for the transceiver.
2. Remove the transceiver from its shipping container and store the packaging material in a safe location.
3. Position the transceiver with the Allied Telesis label facing up. Refer to Figure 77.

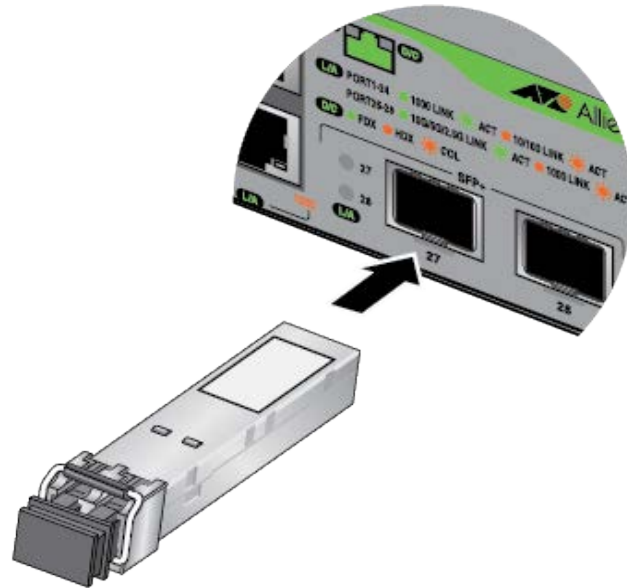

Figure 77. Installing an SFP+ Transceiver

4. Slide the transceiver into the port until it clicks into place.

Note

If you are ready to attach the fiber optic cable to the transceiver, continue with the next step. Otherwise, repeat steps 1 to 4 to install a second transceiver in the switch.

5. Remove the dust cover from the transceiver, as shown in Figure 78 on page 153.

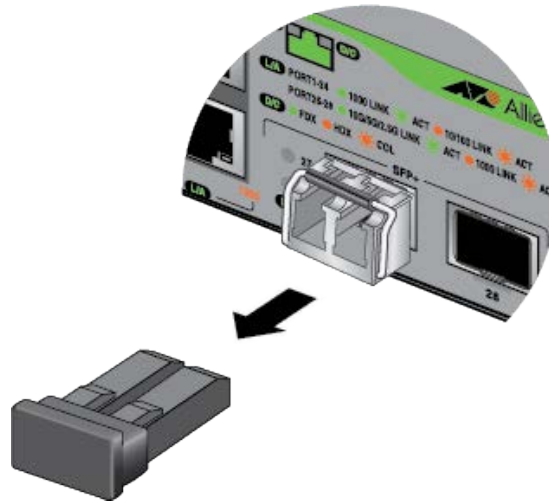

Figure 78. Removing the Dust Cover from an SFP+ Transceiver

6. Verify that the transceiver handle is in the upright position. Refer to Figure 79.

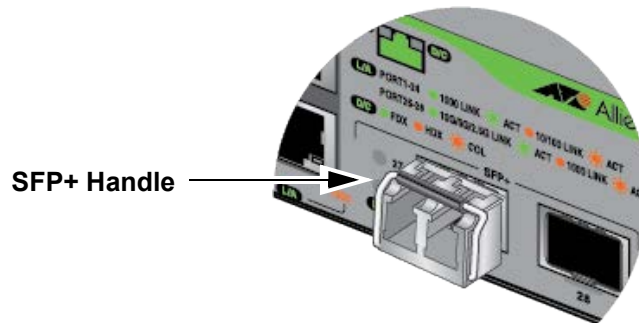

Figure 79. Positioning the SFP+ Handle in the Upright Position

7. Connect the fiber optic cable to the transceiver. Refer to Figure 80 on page 154. The cable connector should fit snugly into the port, and the tab should lock the connector into place.

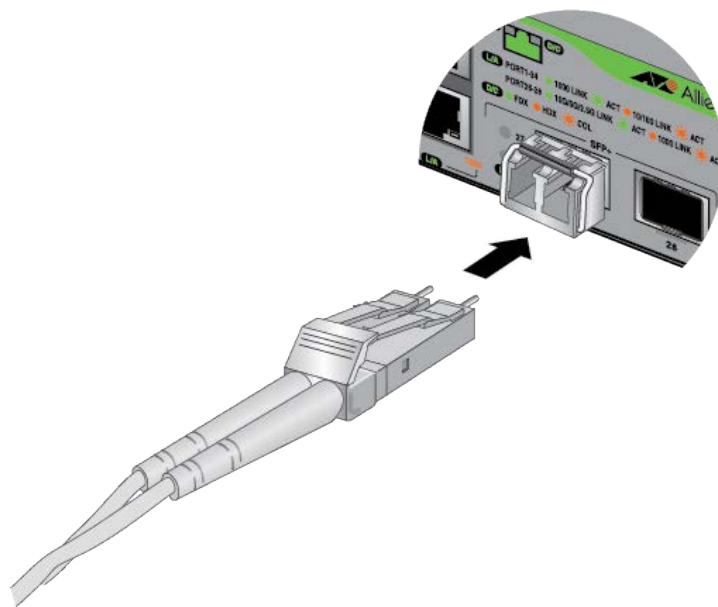

Figure 80. Connecting a Fiber Optic Cable to an SFP or SFP+ Transceiver

8. Repeat this procedure to install a second transceiver.

Installing SP10TW Direct Connect Twinax Cables in SFP+ Ports

The SFP+ ports support SP10TW1 and SP10TW3 direct connect twinax cables. The cables offer an economical way to add 10Gbps connections over short distances. They have SFP+ transceivers on both ends and come in lengths of one and three meters.

Note

The GS970EMX Switches do not support the seven meter SP10TW7 cable.

To install SP10TW cables, perform the following procedure:

1. Select an SFP+ port for the transceiver.
2. Remove the transceiver from its shipping container and store the packaging material in a safe location.
3. Position the transceiver with the Allied Telesis label facing up. Refer to Figure 81.

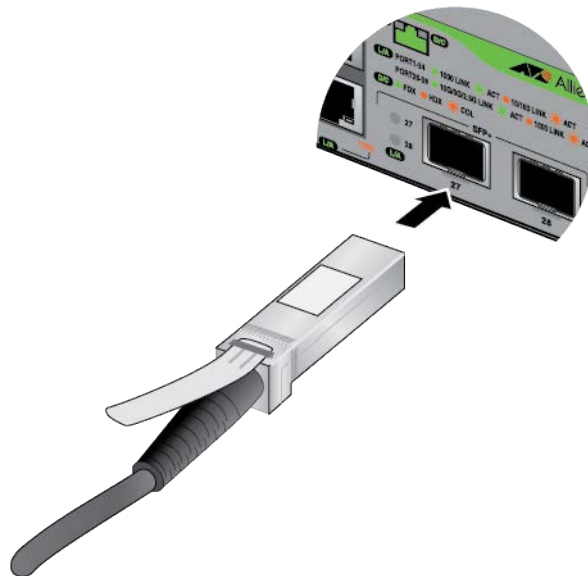

Figure 81. Installing an SP10TW Cable

4. Slide the transceiver into the port until it clicks into place.
5. Connect the other end of the cable into an SFP+ port on another network device.

6. Repeat this procedure to install a second transceiver.

Note

To remove the connector and cable from the port, gently push on the connector, pull on the release tab, and slide the connector from the switch.

Chapter 12

Troubleshooting

This chapter contains suggestions on how to troubleshoot problems with the switch.

Note

For further assistance, contact Allied Telesis Technical Support at www.alliedtelesis.com/us/en/services-support.

Problem 1: The ports are connected to network devices but the port LEDs and Switch ID LED are off.

Solutions: Try the following:

- Verify that the power cord is securely connected to the power source and the AC connector on the back panel of the switch.
- Verify that the power outlet has power by connecting another device to it.
- Try connecting the unit to another power source.
- Try a different power cord.
- Verify that the voltage from the power source is within the required levels for your region. The power requirements for the switch are listed in “Power Specifications” on page 169.
- The switch might be operating in the low power eco-friendly mode. To toggle on the LEDs, press the eco-friendly button on the front panel or enter the NO ECOFRIENDLY LED command in the command line interface.

Problem 2: A copper port is connected to an active network device, but the port’s link/activity and duplex LEDs are off.

Solutions: The port has not established a link to the network device. Try the following:

- Verify that the network device connected to the copper port is powered on and operating properly.
- Try connecting another network device to the port with a different cable. If the port is able to establish a link, then the problem is with the cable or the other network device.
- Verify that the cable does not exceed 100 meters (328 feet).

- ❑ Verify that you are using the appropriate category of cable. Cable requirements are listed in Table 1 on page 26 and Table 2 on page 28.
- ❑ Verify that the port is connected to the correct cable.

Note

Copper ports may require up to five to ten seconds to establish links to network devices.

Problem 3: The link/activity LED for an SFP or SFP+ transceiver is off.

Solutions: The fiber optic port on the transceiver has not established a link to the remote network device. Try the following:

- ❑ Verify that the remote network device connected to the fiber optic port is operating properly.
- ❑ Verify that the fiber optic cable is securely connected to the port on the transceiver and to the port on the remote network device.
- ❑ Check that the transceiver is fully inserted into the port in the switch.
- ❑ Verify that the operating specifications of the fiber optic ports on the transceiver and remote network device are compatible by referring to their documentation.
- ❑ Verify that the correct type of fiber optic cabling is being used.
- ❑ Verify that the port is connected to the correct fiber optic cable.
- ❑ Try connecting another network device to the fiber optic port using a different cable. If the port can establish a link, then the problem is with the cable or remote network device.
- ❑ Use the switch's management software to verify that the port is enabled.
- ❑ If the remote network device is a managed device, use its management firmware to determine whether its port is enabled.
- ❑ If the problem is with two BiDi (bi-directional) transceivers, refer to their data sheets to confirm that their transmission and reception frequencies are opposite each other. For example, a BiDi transceiver that transmits and receives at 1310nm and 1550nm, respectively, has to be connected to a transceiver that transmits and receives at 1550nm and 1310nm, respectively. Two BiDi transceivers that transmit and receive at the same frequencies will not establish a link.
- ❑ Test the attenuation on both directions on the fiber optic cable with a fiber optic tester to determine whether the optical signal is too weak (sensitivity) or too strong (maximum input power).

Problem 4: The switch functions intermittently.

Solutions: Check the system hardware status through the AlliedWare Plus management software:

- ❑ Use the SHOW SYSTEM ENVIRONMENT command in the Privileged Exec mode to verify that the input voltage from the power source to the switch is stable and within the approved operating range. The unit will shut down if the input voltage fluctuates above or below the approved operating range.
- ❑ Verify that the location of the switch allows for adequate airflow. The unit will shut down if it overheats.

Problem 5: The SHOW STACK command is not displaying all the switches in the stack.

Solutions: The switches are unable to form the stack. Try the following:

- ❑ The switches might have different versions of the AlliedWare Plus management software. Use the SHOW VERSION command to display the version numbers. Update the management software, if necessary.
- ❑ If the stack trunk consists of the SFP+ S1 and S2 ports, review “SFP+ Ports S1 and S2” on page 46 and “Unsupported Trunks” on page 51 to confirm that the trunk complies with all the rules and restrictions.
- ❑ If the stack trunk consists of the Multi-Gigabit ports, review “Multi-Gigabit Copper Ports” on page 49 and “Unsupported Trunks” on page 51 to confirm that the trunk complies with all the rules and restrictions.
- ❑ If the stack trunk consists of the SFP+ S1 and S2 ports, verify that the transceivers are from Allied Telesis.
- ❑ If the stack trunk consists of the SFP+ S1 and S2 ports, verify that the transceivers are fully inserted in the switch ports and that the cables are securely connected to the transceivers.
- ❑ Switches might be using different ports as the trunk. All switches of the stack have to be using either the SFP+ S1 and S2 ports or the Multi-Gigabit copper ports for the trunk. Perform the SHOW RUNNING-CONFIG INTERFACE command on switches that did not join the stack to verify that the correct ports have the STACKPORT command, designating them as the stack trunk.

Problem 6: The Switch ID LED on the front of the switch is flashing the letter “F.”

Solutions: The switch is overheating and may have to shut down. The switch’s location is not providing sufficient airflow for ventilation and cooling.

Appendix A

Technical Specifications

This appendix contains the following sections:

- "Physical Specifications" on page 162
- "Environmental Specifications" on page 166
- "Power Specifications" on page 169
- "Certifications" on page 171
- "RJ-45 Copper Port Pinouts" on page 173
- "RJ-45 Style Serial Console Port Pinouts" on page 174

Physical Specifications

Dimensions

Table 16 and Figure 82 and Figure 83 on page 163 provide the dimensions of the switches.

Table 16. Product Dimensions (H x W x D)

GS970EMX/10	3.8 cm x 26.3 cm x 17.9 cm (1.5 in. x 10.4 in. x 7.0 in.)
GS970EMX/20 and GS970EMX/28	4.4 cm x 34.1 cm x 23.1 cm (1.7 in. x 13.4 in. x 9.1 in.)
GS970EMX/52	4.4 cm x 44.1 cm x 32.2 cm (1.7 in. x 17.3 in. x 12.7 in.)

Width

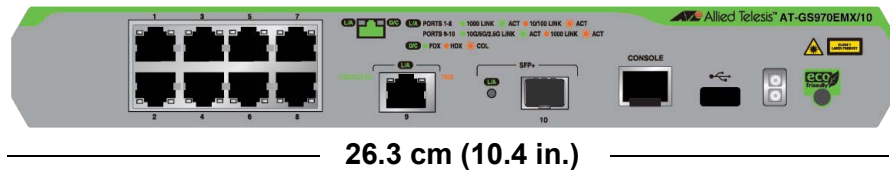

Height

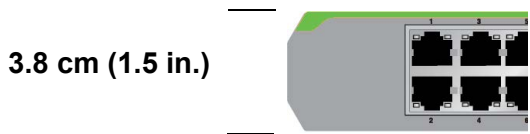

Depth

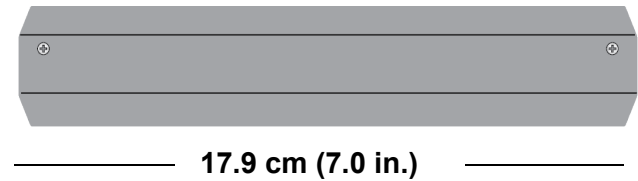
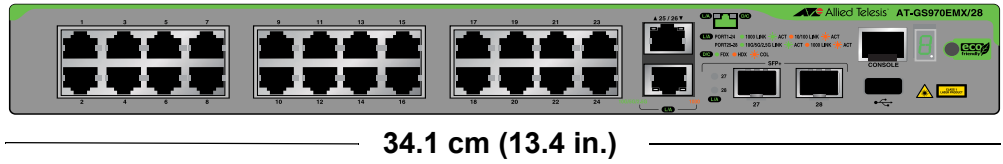

Figure 82. Dimensions of the GS970EMX/10 Switch

Width



Height

4.4 cm (1.7 in.)

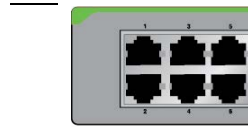

Depth

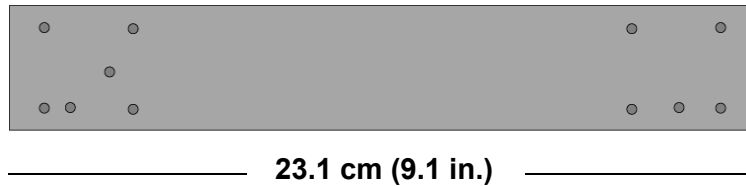
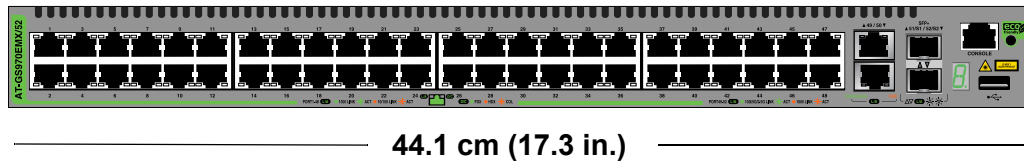

Figure 83. Dimensions of GS970EMX/20 and GS970EMX/28 Switches

Width



Height

4.4 cm (1.7 in.)

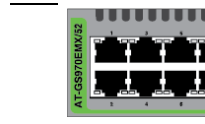

Depth

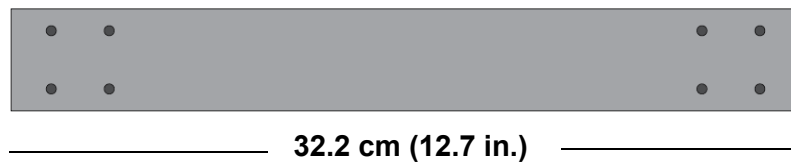

Figure 84. Dimensions of the GS970EMX/52 Switch

Weights

Table 17 lists the switch weights.

Table 17. Switch Weights

GS970EMX/10	1.6 kg (3.53 lb.)
GS970EMX/20	3.0 kg (6.61 lb.)
GS970EMX/28	3.1 kg (6.84 lb.)
GS970EMX/52	4.5 kg (9.92 lb.)

Ventilation

Table 18 lists the ventilation requirements.

Table 18. Ventilation Requirements

Recommended Minimum Ventilation on All Sides	10 cm (4.0 in)
--	----------------

Screw Hole Locations

Measurements in Figure 85 are in millimeters (mm).

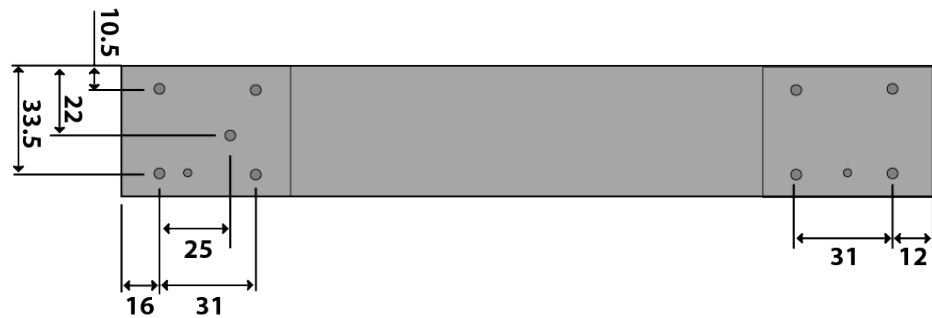

Figure 85. Bracket Screw Holes on GS970EMX/20 and GS970EMX/28 Switches

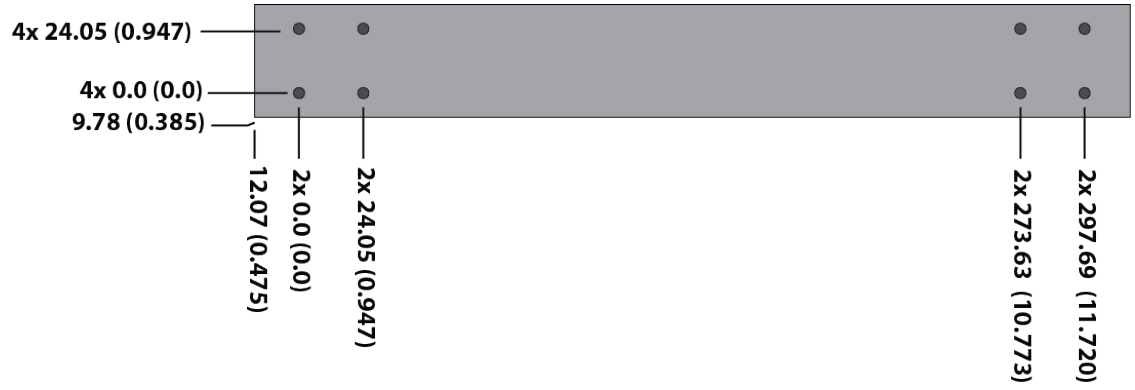

Figure 86. Bracket Screw Holes on the GS970EMX/52 Switch

Environmental Specifications

Table 19 lists the storage and operating environment specifications of the switches.

Table 19. Storage and Operating Environment Specifications

Storage Temperature	-25° C to 70° C (-13° F to 158° F)
Operating Humidity	5% to 90% noncondensing
Storage Humidity	5% to 95% noncondensing
Maximum Operating Altitude	3,000 m (9,842 ft)
Maximum Nonoperating Altitude	4,000 m (13,100 ft)
GS970EMX/52 Switch Noise Level ¹	<42 dB when outside temperature is less than 30° C (86° F) >42 dB when outside temperature is greater than 30° C (86° F)

1. The GS970EMX/52 Switch has a single fan inside the back panel.
The GS970EMX/10, GS970EMX/20, and GS970EMX/28 Switches are fan-less.

Table 20 lists the operating temperature ranges of the switches.

Table 20. Operating Temperature Ranges

GS970EMX/10 Switch	
Table or horizontal equipment rack without an SFP/SFP+ transceiver	0°C to 50°C (32°F to 122°F)
Table or horizontal equipment rack with an SFP/SFP+ transceiver that has a maximum operating temperature of 85°C (185°F)	
Wall or vertical equipment rack without an SFP/SFP+ transceiver	0°C to 45°C (32°F to 113°F)
Wall or vertical equipment rack with an SFP/SFP+ transceiver that has a maximum operating temperature of 70°C (158°F)	

Table 20. Operating Temperature Ranges (Continued)

GS970EMX/20 Switch	
Table, equipment rack, or wall without SFP/SFP+ transceivers	0°C to 50°C (32°F to 122°F)
Table, equipment rack, or wall with SFP/SFP+ transceivers that have a maximum operating temperature of 85°C (185°F)	
Table or horizontal equipment rack with SFP/SFP+ transceivers that have a maximum operating temperature of 70°C (158°F)	
Wall with front panel facing left or down, with SFP/SFP+ transceivers that have a maximum operating temperatures of 85°C (185°F)	
Table or horizontal equipment rack with SFP/SFP+ transceivers that have a maximum operating temperature of 70°C (158°F)	0°C to 45°C (32°F to 113°F)
Wall with front panel facing right or up and with SFP/SFP+ transceivers that have a maximum operating temperature of 70°C (158°F)	
GS970EMX/28 Switch	
Table, equipment rack, or wall with or without SFP/SFP+ transceivers	0°C to 50°C (32°F to 122°F)
Table, equipment rack, or wall with SFP/SFP+ transceivers that have a maximum operating temperature of 85°C (185°F)	
Table or horizontal equipment rack with SFP/SFP+ transceivers that have a maximum operating temperature of 70°C (158°F),	0°C to 45°C (32°F to 113°F)
Wall with the front panel facing left, up, or down and SFP/SFP+ transceivers that have a maximum operating temperature of 70°C (158°F)	

Table 20. Operating Temperature Ranges (Continued)

Wall with front panel facing right and with SFP/SFP+ transceivers that have a maximum operating temperature of 70°C (158°F)	0° C to 40° C (32° F to 104° F)
GS970EMX/52 Switch	
Table, equipment rack, or wall with or without SFP/SFP+ transceivers that have a maximum operating temperature of 85°C (185°F)	0° C to 50° C (32° F to 122° F)
Table, equipment rack, or wall with SFP/SFP+ transceivers that have a maximum operating temperature of 70°C (158°F)	0°C to 45°C (32°F to 113°F)

Power Specifications

This section contains the maximum power consumption values, input voltages, and heat dissipation values.

Maximum Power Consumptions

Table 21 lists the maximum power consumptions of the switch.

Table 21. Maximum Power Consumption

GS970EMX/10	21 watts
GS970EMX/20	28 watts
GS970EMX/28	33 watts
GS970EMX/28	52 watts

Input Voltages

Table 22 lists the input voltage of the switch.

Table 22. Input Voltages

GS970EMX/10	100-240 VAC~, 0.5A maximum, 50/60 Hz
GS970EMX/20	100-240 VAC~, 0.7A maximum, 50/60 Hz
GS970EMX/28	100-240 VAC~, 0.8A maximum, 50/60 Hz
GS970EMX/52	100-240 VAC~, 0.7A maximum, 50/60 Hz

Note

The input voltage, current, and frequency can be found on the rating label on the bottom panel of the switch.

Heat Dissipation

Table 23 lists the heat dissipation.

Table 23. Heat Dissipation

GS970EMX/10	71 BTU/hr
GS970EMX/20	96 BTU/hr
GS970EMX/28	114 BTU/hr
GS970EMX/52	181 BTU/hr

Certifications

Table 24 lists the product certificates.

Table 24. Product Certifications

Additional Certificates	CISPR Class A (Comité International Spécial des Perturbations Radioélectriques) Compliant with European and China RoHS standards
Australia/New Zealand	RCM (Regulatory Compliance Mark)
Common Criteria	NIAP (National Information Assurance Partnership)
European Economic Area (EEA)	CE (Conformité Européenne) WEEE (Waste Electrical and Electronic Equipment) RoHS (EU 1025/863) (Restriction of Hazardous Substances)
European Standards (EN)	EMC (Immunity): EN 55024, EN 55035 Laser Safety: EN 60825-1 EN 55032 Class A, EN 61000-3-2, EN 61000-3-3 Electrical Safety: EN 62368-1 (UL/ EN/IEC)
India	TEC (Telecommunications Engineering Center)
Japan	VCCI Class A (Voluntary Control Council for Interference)

Table 24. Product Certifications (Continued)

Mexico	NOM (Normas Oficiales Mexicanas)
North America	FCC Class A Laser Safety: EN 60825-1 cULus Energy Star
United Kingdom	UKCA (UK Conformity Assessment)

RJ-45 Copper Port Pinouts

Figure 87 illustrates the pin layout of the RJ-copper ports.

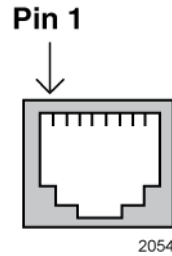

Figure 87. Pin Layout for the RJ-45 Copper Ports (Front View)

Table 25 lists the pin signals for the copper ports.

Table 25. Pin Signals for Copper Ports

Pin	10/100Mbps MDI	10/100Mbps MDI-X	1/2.5/5/10Gbps
1	TX+	RX+	Bi-directional pair A+
2	TX-	RX-	Bi-directional pair A-
3	RX+	TX+	Bi-directional pair B+
4	Not used	Not used	Bi-directional pair C+
5	Not used	Not used	Bi-directional pair C-
6	RX-	TX-	Bi-directional pair B-
7	Not used	Not used	Bi-directional pair D+
8	Not used	Not used	Bi-directional pair D-

RJ-45 Style Serial Console Port Pinouts

Table 26 lists the pin signals of the RJ-45 style serial Console port.

Table 26. RJ-45 Style Serial Console Port Pin Signals

Pin	Signal
1	Unused
2	Unused
3	Transmit Data
4	Signal Ground
5	Signal Ground
6	Receive Data
7	Unused
8	Unused
9	N/A